



VS-616G5 Series (Revision F)

Installation & Quick-Start Manual

General Purpose Flux Vector Inverter with AVC™

This page intentionally left blank.

WARNING

PRECAUTIONS

- 1) Read this manual in its entirety before installing or operating the VS-616G5 inverter.
- 2) Do not connect or disconnect wiring, or perform signal checks while the power supply is turned ON.
- 3) The VS-616G5 internal capacitor is still charged even after the power supply is turned OFF. To prevent electrical shock, disconnect all power before servicing the inverter. Then wait at least one minute after the power supply is disconnected and all LED's are extinguished.
- 4) Do not perform a withstand voltage test or a megger test on any part of the VS-616G5. This electronic equipment uses semiconductors and is vulnerable to high voltage.
- 5) Do not remove the operator unless the power supply is turned OFF. Never touch the printed control board while the power supply is turned ON.
- 6) The VS-616G5 is suitable for use on a circuit capable of delivering not more than 65,000 RMS symmetrical amperes, 600 Volts maximum (575V class units), 480 Volts maximum (460V class units), and 240 Volts maximum (230V class units).

Failure to observe these and other precautions highlighted in this manual will expose the user to high voltages, resulting in equipment damage, serious injury or death.

NOTICE

Printed April 1999. The information contained within this document is the proprietary property of Yaskawa Electric America, Inc., and may not be copied, reproduced or transmitted to other parties without the expressed written authorization of Yaskawa Electric America, Inc.

No patent liability is assumed with respect to the use of the information contained herein. Moreover, because Yaskawa is constantly improving its high-quality products, the information contained in this manual is subject to change without notice. Every precaution has been taken in the preparation of this manual. Nevertheless, Yaskawa assumes no responsibility for errors or omissions. Neither is any liability assumed for damages resulting from the use of the information contained in this publication.

CONTENTS

<u>Section</u>	<u>Description</u>	<u>Page</u>
1	RECEIVING & INSTALLATION	
1.1	INTRODUCTION	7
1.2	SOFTWARE VERSION EXPLANATION	8
1.3	VS-616G5 SPECIFICATIONS	9
1.4	PRELIMINARY INSPECTION	12
	Receiving	12
	Checking the Nameplate	12
	Identifying the Parts	12
1.5	MOUNTING	13
	Precautions	13
	Choosing a Location	13
	Removing and Replacing the Digital Operator	14
	Removing and Replacing the Front Cover	15
	Dimensions/Heat Loss	15
	Clearances	19
1.6	WIRING	20
	Precautions	20
	Inspection	20
	Standard Connection Diagrams	21
	Main Circuit Diagrams	24
	Main Circuit Wiring	27
	Terminal Functions	29
	Wire and Terminal Screw Sizes	31
	Control Circuit Wiring	35
2	OPERATION	
	Precautions	38
2.1	TRIAL OPERATION	39
	Digital Operator Display at Power-up	39
	Operation Checkpoints	40
	Operation by Digital Operator	40
	Operation by Control Circuit Terminal Signal	42
2.2	DIGITAL OPERATOR DISPLAY	43
2.3	OPERATION MODE SELECTION	44
3	QUICK-START PROGRAMMING	
	Quick-Start Parameter Sequence	46
3.1	MAIN MENU: INITIALIZE	47
3.2	MAIN MENU: PROGRAMMING	48
3.3	MAIN MENU: AUTO-TUNING	59

4	DIAGNOSTICS	
	Precautions	62
4.1	MAINTENANCE & INSPECTION	63
	Periodic Inspection	63
	Parts Replacement Schedule	63
4.2	ALARM & FAULT DISPLAY	64
	Inverter Alarms & Faults	64
	Motor Faults	68
A	APPENDIX	
A.1	VS-616G5 PARAMETER TREE	70
A.2	VS-616G5 MONITOR DISPLAY	71
A.3	VS-616G5 PARAMETERS	76
A.4	BRAKING CONNECTION DIAGRAMS	107
A.5	CE CONFORMANCE INFORMATION	108

- CHAPTER 1 -

RECEIVING & INSTALLATION

<u>Section</u>	<u>Description</u>	<u>Page</u>
1	RECEIVING & INSTALLATION	
1.1	INTRODUCTION	7
1.2	SOFTWARE VERSION EXPLANATION	8
1.3	VS-616G5 SPECIFICATIONS	9
1.4	PRELIMINARY INSPECTION	12
	Receiving	12
	Checking the Nameplate	12
	Identifying the Parts	12
1.5	MOUNTING	13
	Precautions	13
	Choosing a Location	13
	Removing and Replacing the Digital Operator	14
	Removing and Replacing the Front Cover	15
	Dimensions/Heat Loss	15
	Clearances	19
1.6	WIRING	20
	Precautions	20
	Inspection	20
	Standard Connection Diagrams	21
	Main Circuit Diagrams	24
	Main Circuit Wiring	27
	Terminal Functions	29
	Wire and Terminal Screw Sizes	31
	Control Circuit Wiring	35

1.1 INTRODUCTION

The VS-616G5, a series of high quality, general-purpose inverters with flux vector control, directly controls the current (or torque) in an AC induction motor. With an initial power range of 0.5 to 500 HP, it is suited for any application, and provides smooth start-up at low speeds, and extremely precise operation. It's proprietary auto-tuning function enables high-performance tuning of motors manufactured worldwide.

The VS-616G5 combines four control methods into one compact drive, including flux vector and conventional V/f control. From precision machinery to multiple motor drives, the VS-616G5 proves to be the *Ultimate* drive for any application. This functionality includes Yaskawa proprietary features like Adaptive Vector Control (AVC™), full-range automatic torque boost, auto-tuning, UL-recognized electronic thermal motor overload, energy savings operation, PID control, low-noise operation and various other features. It also features a 2-line × 16-character, alphanumeric digital operator for simple programming in seven different languages. Utilizing the latest microprocessor technology, members of Yaskawa's design team have collaborated to make the VS-616G5 the *Ultimate* drive for *any* application.

This manual details installation, quick-start and diagnostic procedures for the VS-616G5 series adjustable frequency drive controller. For more detailed descriptions of programming procedures, contact your Yaskawa representative.

1.2 SOFTWARE VERSION EXPLANATION

Yaskawa recognizes the need to continuously improve product quality. This product may receive feature enhancements in the form of software or hardware changes. New programming parameters will be added to the latest programming manual. When a new parameter is added a software version note will be placed next to the parameter.

Software Version Example:

For Parameter A1-00, select the language displayed on the digital operator according to the following table:

Setting	Description
0	English (<i>factory default</i>)
1	Japanese
2	Deutsche <1110>*
3	Francais <1110>*
4	Italiano <1110>*
5	Espanol <1110>*
6	Portugues <1110>*

*This version note <1110> indicates that five additional languages have been added with software version 1110.

The part number of the main control printed circuit board on the drive reflects the software version. The software version normally increases to a higher number with newer versions. Please consult the factory for details.

PCB Part Number Example: ETC615991-S1110 represents software version 1110.

The VS-616G5 ships preset to open loop vector control, quick-start access level.

1.3 VS-616G5 SPECIFICATIONS

230V

Inverter Model CIMR-G5U		VS-616G5															
		20P4	20P7	21P5	22P2	23P7	25P5	27P5	2011	2015	2018	2022	2030	2037	2045	2055	2075
Output Characteristics	Nominal Motor Output (HP) *	0.5	1	2	3	5	7.5	10	15	20	25	30	40	50	60	75	100
	Capacity (kVA)**	1.2	2.3	3.0	4.2	6.7	9.5	13	19	24	30	37	50	61	70	85	110
	Rated Output Current (A) #	3.2	6	8	11	17.5	25	33	49	64	80	96	130	160	183	224	300
	Max. Voltage	3-Phase, 200/208/220/230V (Proportional to input voltage)															
	Rated Output Frequency	Up to 400 Hz available															
Overload Capacity	150% Rated Current / 1 minute																
Power Supply	Input Current (A)	3.9	7.2	9.6	13.2	21	30	40	59	77	88	106	143	176	202	247	330
	Rated Voltage & Frequency	3-Phase 200 to 230V, 50/60Hz															
	Voltage Fluctuation	+10%, -15%															
	Frequency Fluctuation	±5%															

460V

CIMR-G5U		40P4	40P7	41P5	42P2	43P7	44P0	45P5	47P5	4011	4015	4018	4022	4030	4037	4045	4055	4075	4110	4160	4185	4220	4300
Output Characteristics	Nominal Motor Output (HP) *	0.5	1	2	3	5	7.5	10	15	20	25	30	40	50	60	75	100	125	150	200	250	350	500
	Capacity (kVA)**	1.4	2.6	3.7	4.7	6.1	8.4	11	16	21	26	31	40	50	61	73	98	130	170	230	260	340	460
	Rated Output Current (A) #	1.9	3.6	5.1	6.6	8.5	11.7	14.8	21	28.6	34	41	52	65	80	96	128	165	224	302	340	450	605
	Max. Voltage	3-Phase, 380/400/415/440/460V (Proportional to input voltage)																					
	Rated Output Frequency	Up to 400 Hz available																					
Overload Capacity	150% Rated Current / 1 minute																						
Power Supply	Input Current (A)	2.3	4.3	6.1	8	10.2	14	17.8	26	35	40	46	58	72	88	106	141	182	247	330	408	540	726
	Rated Voltage & Frequency #	3-Phase 380 to 460V, 50/60Hz																					
	Voltage Fluctuation	+10%, -15%																					
	Frequency Fluctuation	±5%																					

* HP ratings based on NEMA 4-pole motor data. However, when sizing a drive to match a motor, use output current ratings.

For proper operation, the motor rated current must be less than or equal to the inverter rated current.

** kVA ratings are based on 200V, 400V, and 600V inputs respectively.

VS-616G5 SPECIFICATIONS (continued)
 575V

Inverter Model CIMR-G5U		VS-616G5																	
		51P5	52P2	53P7	55P5	57P5	5011	5015	5018	5022	5030	5037	5045	5055	5075	5090	5110	5160	
Output Characteristics	Nominal Motor Output (HP) *	Constant Torque	2	3	5	7.5	10	15	20	25	30	40	50	60	75	100	125	150	200
		Variable Torque	3	3	5	10	10	15	20	25	30	40	50	60	75	100	150	200	200
	Capacity (kVA) **	2	3	5	7.5	10	15	20	25	30	40	50	60	75	100	125	150	200	
	Rated Output Current (A) #	Constant Torque (A)	3.5	4.1	6.3	9.8	12.5	17	22	27	32	41	52	62	77	99	130	172	200
		Variable Torque (A)	3.9	4.6	7	11	14	19	25	30	36	46	58	69	86	111	145	192	224
	Maximum Voltage	3-Phase, 500/575/600V(Proportional to input voltage)																	
Rated Output Frequency	Up to 400 Hz available																		
Overload Capacity	150% Rated Current / 1 minute (CT rating) 120% Rated Current / 1 minute (VT rating)																		
Power Supply	Input Current (A)	4.3	5.1	7.7	12.1	15.4	21	28	33	40	51	64	76	95	122	160	211	246	
	Rated Voltage & Frequency	3-Phase, 500 to 600V, 50/60Hz																	
	Voltage Fluctuation	+10%, -15%																	
	Frequency Fluctuation	±5%																	

* HP ratings based on NEMA 4-pole motor data. However, when sizing a drive to match a motor, use output current ratings.

For proper operation, the motor rated current must be less than or equal to the inverter rated current.

** kVA ratings are based on 200V, 400V, and 600V inputs respectively.

VS-616G5 SPECIFICATIONS (continued)

Control Characteristics	Control Method	Sine wave PWM
	Starting Torque	150% below 1Hz (150% at 0 rpm with PG)
	Speed Control Range	100:1 (1000:1 with PG)
	Speed Control Accuracy	±0.2% (±0.02% with PG)
	Speed Response	5Hz (30Hz with PG)
	Torque Limit	Can be set by parameter: 4 quadrant control
	Torque Accuracy	±5%
	Torque Response	20Hz (40Hz with PG)
	Frequency Control Range	0.1 to 400 Hz
	Frequency Accuracy	Digital command: 0.01%, Analog command: 0.1%
	Frequency Setting Resolution	Digital Operator Reference: 0.01Hz Analog Reference: 0.03Hz (@60Hz)
	Output Frequency Resolution	0.01 Hz
	Frequency Setting Signal	-10 to +10V, 0 to +10V, 4 to 20mA
	Accel/Decel Time	0.0 to 6000.0 sec. (Accel/Decel time setting independently, 4 steps available)
Braking Torque	Approx. 20%	
Protective Functions	Motor Overload Protection	UL-recognized electronic thermal overload relay (I^2T)
	Instantaneous Overcurrent	Motor coasts to stop at approximately 200% rated output current. (CT Rating)
	Fuse Protection	Motor coasts to stop at blown fuse.
	Overload	Motor coasts to stop after 1 min. at 150% rated output current. (CT Rating)
	Overvoltage	Motor coasts to stop if converter output voltage exceeds 410VDC (820VDC at 460V input, 1040VDC at 575V input)
	Undervoltage	Motor coasts to stop if converter output voltage drops below user adjustable value
	Momentary Power Loss	Immediately stop after 15 ms or longer power loss. (Continuous system operation during power loss less than 2s is equipped as standard.)
	Heatsink Overheat	Thermistor - OH1, OH2
	Stall Prevention	Stall prevention during acceleration, deceleration and constant speed operation
	Ground Fault	Provided by electronic circuit (overcurrent level)
	Power Charge Indication	Charge LED stays on until bus voltage drops below 50VDC
	Input Phase Loss	Single-phase protection
Environmental Conditions	Location	Indoor (protected from corrosive gases and dust)
	Ambient Temperature	+14 to 104°F (-10 to 40°C) for NEMA 1 type +14 to 113°F (-10 to 45°C) for Open Chassis type
	Storage Temperature	-4 to 140°F (-20 to 60°C)
	Humidity	95% RH (non-condensing)
	Vibration	9.8m/s ² (1G) less than 20Hz, up to 1.96m/s ² (0.2G) at 20 to 50Hz

1.4 PRELIMINARY INSPECTION

Receiving

After unpacking the VS-616G5:

- Verify that the part numbers on the drive nameplate match the numbers on your purchase order or packing slip.
- Check the unit for physical damage which may have occurred during shipping. If any part of the drive is missing or damaged, notify the carrier and your Yaskawa representative immediately.
- Verify that all internal hardware (i.e. components, screws, etc.) is seated properly and fastened securely.
- Verify that the instruction manual is included (YEA-TOA-S616-10.12).
- If the drive will be stored after receiving, place it in its original packaging and store according to temperature specifications on page 11.

Checking the Nameplate

Inverter Model →	MODEL : CIMR-G5U43P7 SPEC : 43P71F_	← Inverter Spec.
Input Spec. →	INPUT : AC 3PH 380-440V 50Hz 10.2A 380-460V 60Hz	
Output Spec. →	OUTPUT : AC 3PH 0-460V 6.1kVA 8.5A	
Lot No. →	LOT NO : _____	← Mass
Serial No. →	SER NO : _____	
UL File No. →	UL FILE NO : E131457	Mg

Figure 1 Nameplate Example of American Model CIMR-G5U43P7

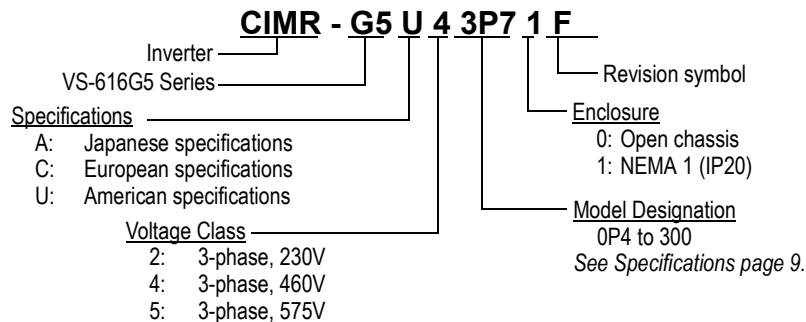

Figure 2 Nameplate Description

Identifying the Parts

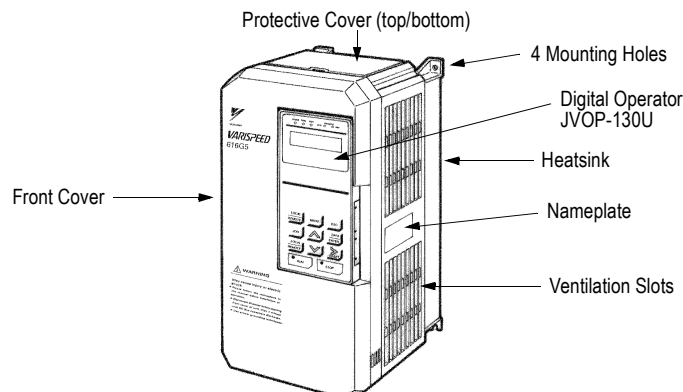

Figure 3 Parts Identification - Model CIMR-G5U43P7

1.5 MOUNTING

CAUTION

PRECAUTIONS

- 1) When preparing to mount the VS-616G5, lift it by its base. Never lift it by the front cover.
- 2) Mount the inverter onto nonflammable material.
- 3) The VS-616G5 generates heat. For the most effective cooling possible, mount it vertically. For more details, refer to “Dimensions/Heat Loss” on pages 15-18 and “Clearances” on page 19. For mounting configurations other than normal vertical mounting, please consult the factory.
- 4) When mounting units in an enclosure, install a fan or other cooling device to keep the intake air temperature below 113°F (45°C).

Failure to observe these precautions may result in equipment damage.

Choosing a Location

Be sure that the inverter is mounted in a location protected against the following conditions:

- Extreme cold and heat. Use only within the ambient temperature range:
 - NEMA 1: 14 to 104°F (-10 to 40°C).
 - Open Chassis: 14 to 113°F (-10 to 45°C)
- Direct sunlight (not for use outdoors)
- Rain, moisture
- High humidity
- Oil sprays, splashes
- Salt spray
- Dust or metallic particles in the air
- Corrosive gases (e.g. sulfurized gas) or liquids
- Radioactive substances
- Combustibles (e.g. thinner, solvents, etc.)
- Physical shock, vibration
- Magnetic noise (e.g. welding machines, power devices, etc.)

Removing and Replacing the Digital Operator

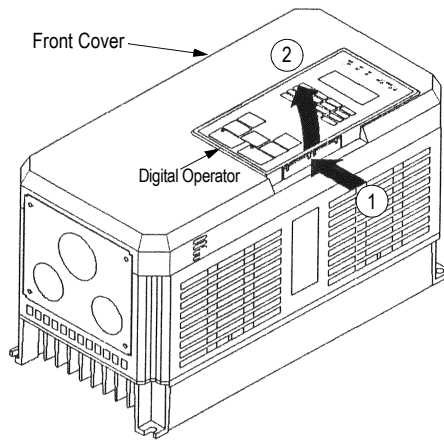

To remove the digital operator from the front cover, push the operator retaining tab in the direction shown by arrow 1 and lift the digital operator in the direction shown by arrow 2.

Figure 4 Removing the Digital Operator

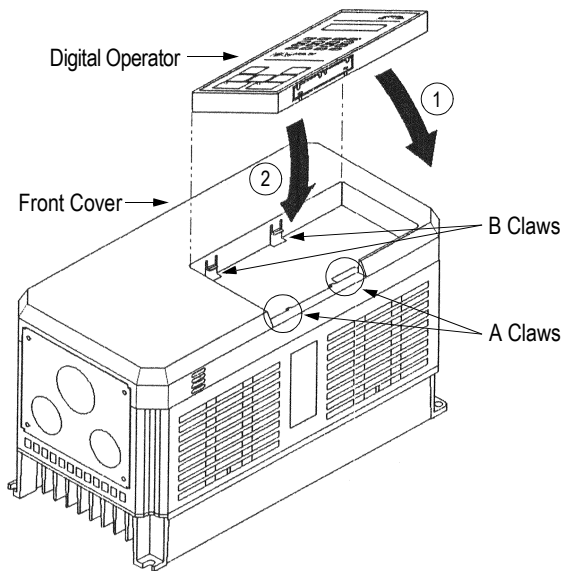

To replace the digital operator, engage the operator onto the A tabs in the direction shown by arrow 1 and then press the operator onto the B tabs in the direction shown by arrow 2, locking the digital operator into place.

Figure 5 Replacing the Digital Operator

Removing and Replacing the Front Cover

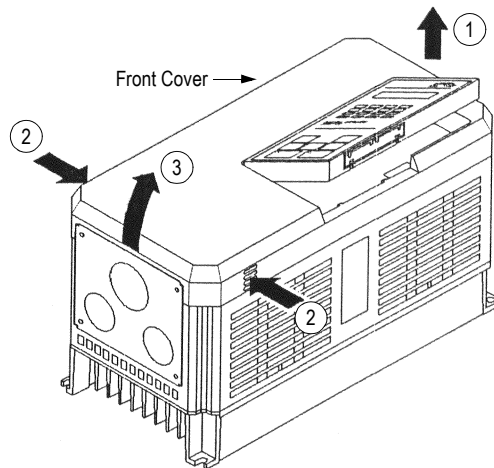

To remove the front cover, first remove the digital operator (see previous section). Then squeeze the cover on both sides in the direction shown by arrows 2 and lift the cover in the direction shown by arrow 3.

Figure 6 Removing and Replacing the Front Cover

Dimensions/Heat Loss

Dimensions/Heat Loss (Continued)

Open Chassis Type (IP00)

Open Chassis Type (IP00)

Voltage	Model CIMR- G5U	Open Chassis Dimensions in inches (mm)						Mass lbs (kg)	Heat Loss (W)		
		W	H	D	W1	H1	H2		Heat sink	Inside unit	Total
230V	20P4	5.51 (140)	11.02 (280)	6.30 (160)	4.96 (126)	10.47 (266)	0.28 (7)	6.5 (3)	15	50	65
	20P7								25	65	90
	21P5								40	80	120
	22P2	5.51 (140)	11.02 (280)	7.09 (180)	4.96 (126)	10.47 (266)	0.28 (7)	10 (4.5)	80	60	140
	23P7								135	80	215
	25P5	7.87 (200)	11.81 (300)	8.07 (205)	7.32 (186)	11.22 (285)	0.31 (8)	12 (5.5)	210	90	300
	27P5								235	110	345
	2011	9.84 (250)	14.96 (380)	8.86 (225)	9.29 (236)	14.37 (365)	0.30 (7.5)	24 (11)	425	160	585
	2015								525	200	725
	2018								655	230	885
	2022	12.80 (325)	17.72 (450)	11.22 (285)	10.83 (275)	17.13 (435)	0.30 (7.5)	62 (28)	830	280	1110
	2030	16.73 (425)	26.57 (675)	13.78 (350)	12.60 (320)	25.59 (650)	0.49 (12.5)	134 (61)	930	440	1370
	2037								1110	620	1730
	2045	18.70 (475)	31.50 (800)	13.78 (350)	14.57 (370)	30.51 (775)	0.49 (12.5)	176 (80)	1380	660	2040
2055	1740								890	2630	
2075	22.64 (575)	36.42 (925)	15.75 (400)	17.52 (445)	35.24 (895)	0.59 (15)	298 (135)	2050	1160	3210	
460V	40P4	5.51 (140)	11.02 (280)	6.30 (160)	4.96 (126)	10.47 (266)	0.28 (7)	6.5 (3)	10	50	60
	40P7								20	65	85
	41P5								8.8 (4)	30	80
	42P2	5.51 (140)	11.02 (280)	7.09 (180)	4.96 (126)	10.47 (266)	0.28 (7)	10 (4.5)	65	60	125
	43P7								80	65	145
	44P0								120	80	200
	45P5	7.87 (200)	11.81 (300)	8.07 (205)	7.32 (186)	11.22 (285)	0.31 (8)	13 (6)	135	85	220
	47P5								240	120	360
	4011	9.84 (250)	14.96 (380)	8.86 (225)	9.29 (236)	14.37 (365)	0.30 (7.5)	24 (11)	305	150	455
	4015								390	180	570
	4018								465	195	660
	4022	12.80 (325)	17.72 (450)	11.22 (285)	10.83 (275)	17.13 (435)	0.30 (7.5)	60 (27)	620	260	880
	4030	12.80 (325)	24.61 (625)	11.22 (285)	10.83 (275)	24.02 (610)	0.30 (7.5)	97 (44)	705	315	1020
	4037								875	370	1245
	4045								970	415	1385
	4055	17.91 (455)	32.28 (820)	13.78 (350)	13.78 (350)	31.30 (795)	0.49 (12.5)	174 (79)	1110	710	1820
	4075								1430	890	2320
	4110	22.64 (575)	36.42 (925)	14.76 (375)	17.52 (445)	35.24 (895)	0.59 (15)	298 (135)	1870	1160	3030
	4160			15.75 (400)					320 (145)	2670	1520
	4185	37.40 (950)	57.09 (1450)	17.13 (435)	29.53 (750)	55.12 (1400)	0.98 (25)	794 (360)	3400	1510	4910
4220	4740								2110	6850	
4300	6820								2910	9730	

Voltage	Model CIMR- G5U	Open Chassis Dimensions in inches (mm)						Mass lbs (kg)	Heat Loss (W)		
		W	H	D	W1	H1	H2		Heat sink	Inside unit	Total
575V	51P5	5.51 (140)	11.02 (280)	7.09 (180)	4.96 (126)	10.47 (266)	0.28 (7)	8.8 (4)	35	55	90
	52P2								45	60	105
	53P7	7.87 (200)	11.81 (300)	8.07 (205)	7.32 (186)	11.22 (285)	0.31 (8)	13 (6)	65	75	140
	55P5								100	105	205
	57P5								130	90	220
	5011	9.84 (250)	14.96 (380)	8.86 (225)	9.29 (236)	14.37 (365)	0.29 (7.5)	28 (13)	180	150	330
	5015								250	210	460
	5018	15.75 (400)	29.53 (750)	11.22 (285)	11.81 (300)	28.74 (730)	0.39 (10)	97 (44)	310	230	540
	5022								380	340	730
	5030								430	390	820
	5037	22.64 (575)	33.46 (850)	11.81 (300)	18.70 (475)	32.48 (825)	0.49 (12.5)	156 (72)	680	540	1220
	5045								900	750	1650
	5055	22.64 (575)	41.34 (1050)	12.80 (325)	18.70 (475)	40.35 (1025)	0.49 (12.5)	195 (90)	1000	750	1750
	5075								1100	1150	2250
	5090	22.64 (575)	49.21 (1250)	12.99 (330)	18.70 (475)	48.23 (1225)	0.49 (12.5)	262 (121)	1150	1200	2350
	5110	22.64 (575)	62.99 (1600)	13.98 (355)	18.70 (475)	61.81 (1570)	0.59 (15)	318 (147)	1400	1800	3200
5160	1870								2830	4700	

Dimensions/Heat Loss (Continued)

Enclosed Type (NEMA 1, IP20)

Voltage	Model (CIMR-G5)	NEMA 1 Dimensions in inches (mm)						Mass lbs (kg)
		W	H	D	W1	H1	H2	
230V	20P4	5.51 (140)	11.02 (280)	6.30 (160)	4.96 (126)	10.47 (266)	0.28 (7)	6.5 (3)
	20P7							
	21P5							
	22P2	5.51 (140)	11.02 (280)	7.09 (180)	4.96 (126)	10.47 (266)	0.28 (7)	10 (4.5)
	23P7							
	25P5	7.87 (200)	11.81 (300)	8.07 (205)	7.32 (186)	11.22 (285)	0.31 (8)	12 (5.5)
	27P5							13 (6)
	2011	9.84 (250)	14.96 (380)	8.86 (225)	9.29 (236)	14.37 (365)	0.30 (7.5)	24 (11)
	2015		15.75 (400)				1.08 (27.5)	
	2018	12.99 (330)	24.02 (610)	11.22 (285)	10.83 (275)	17.13 (435)	3.44 (87.5)	71 (32)
	2022		26.57 (675)				6.00 (152.5)	
	2030	16.93 (430)	38.78 (985)	13.78 (350)	12.60 (320)	25.59 (650)	8.37 (212.5)	148 (67)
	2037							150 (68)
	2045	18.90 (480)	43.70 (1110)	13.78 (350)	14.57 (370)	30.51 (775)	8.37 (212.5)	192 (87)
	2055							
2075	22.83 (580)	50.79 (1290)	15.75 (400)	17.52 (445)	35.24 (895)	10.63 (270)	320 (145)	

Dimensions/Heat Loss (Continued)

Enclosed Type (NEMA 1, IP20) (Continued)

Voltage	Model (CIMR-G5)	NEMA 1 Dimensions in inches (mm)						Mass lbs (kg)
		W	H	D	W1	H1	H2	
460V	40P4	5.51 (140)	11.02 (280)	6.30 (160)	4.96 (126)	10.47 (266)	0.28 (7)	6.5 (3)
	40P7							
	41P5	5.51 (140)	11.02 (280)	7.09 (180)	4.96 (126)	10.47 (266)	0.28 (7)	8.8 (4)
	42P2							
	43P7							
	44P0							
	45P5							
	47P5	7.87 (200)	11.81 (300)	8.07 (205)	7.32 (186)	11.22 (285)	0.31 (8)	13 (6)
	4011	9.84 (250)	14.96 (380)	8.86 (225)	9.29 (236)	14.37 (365)	0.30 (7.5)	24 (11)
	4015							
	4018	12.99 (330)	24.02 (610)	11.22 (285)	10.83 (275)	17.13 (435)	3.44 (87.5)	68 (31)
	4022							
	4030	12.99 (330)	30.91 (785)	11.22 (285)	10.83 (275)	24.02 (610)	3.44 (87.5)	106 (48)
	4037							
	4045							
	4055	18.11 (460)	44.49 (1130)	13.78 (350)	13.78 (350)	31.30 (795)	8.37 (212.5)	187 (85)
	4075							190 (86)
	4110	22.83 (580)	50.79 (1290)	14.76 (375)	17.52 (445)	35.24 (895)	10.63 (270)	320 (145)
4160	15.75 (400)			342 (155)				
575V	51P5	5.51 (140)	11.02 (280)	7.09 (180)	4.96 (126)	10.47 (266)	0.28 (7)	8.8 (4)
	52P2							
	53P7	7.87 (200)	11.81 (300)	8.07 (205)	7.32 (186)	11.22 (285)	0.31 (8)	13 (6)
	55P5							
	57P5							14 (6.5)
	5011	9.84 (250)	14.96 (380)	8.86 (225)	9.29 (236)	14.37 (365)	0.29 (7.5)	28 (13)
	5015							
	5018	15.75 (400)	29.53 (750)	11.22 (285)	11.81 (300)	28.74 (730)	0.39 (10)	97 (44)
	5022							
	5030	22.64 (575)	33.46 (850)	11.81 (300)	18.70 (475)	32.48 (825)	0.49 (12.5)	156 (72)
	5037							
	5045							
	5055	22.64 (575)	41.34 (1050)	12.80 (325)	18.70 (475)	40.35 (1025)	0.49 (12.5)	195 (90)
	5075		41.97 (1066)					
	5090	22.80 (579)	57.68 (1465)	12.99 (330)	18.70 (475)	48.23 (1225)	0.49 (12.5)	271 (125)
	5110	22.80 (579)	77.43 (1966.5)	13.98 (355)	18.70 (475)	61.81 (1570)	0.59 (15)	331 (153)
5160	342 (158)							

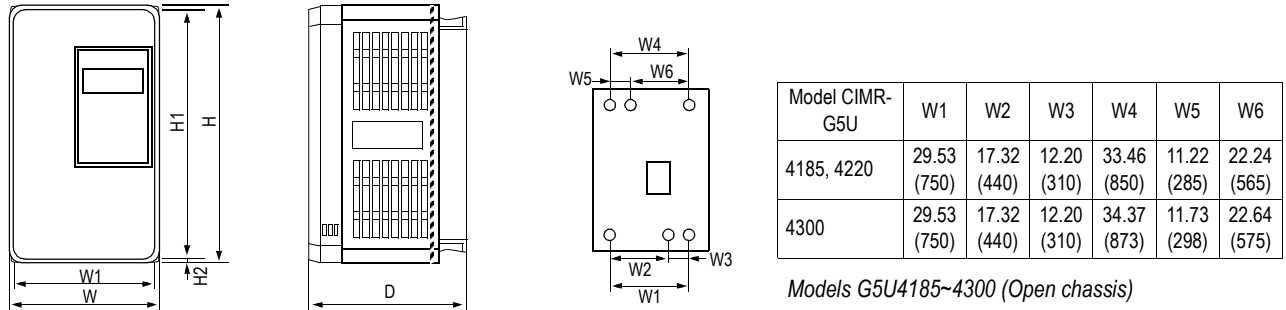

Figure 7 VS-616G5 Dimension Diagram

Clearances

When mounting the VS-616G5, allow sufficient clearances for effective cooling as shown below:

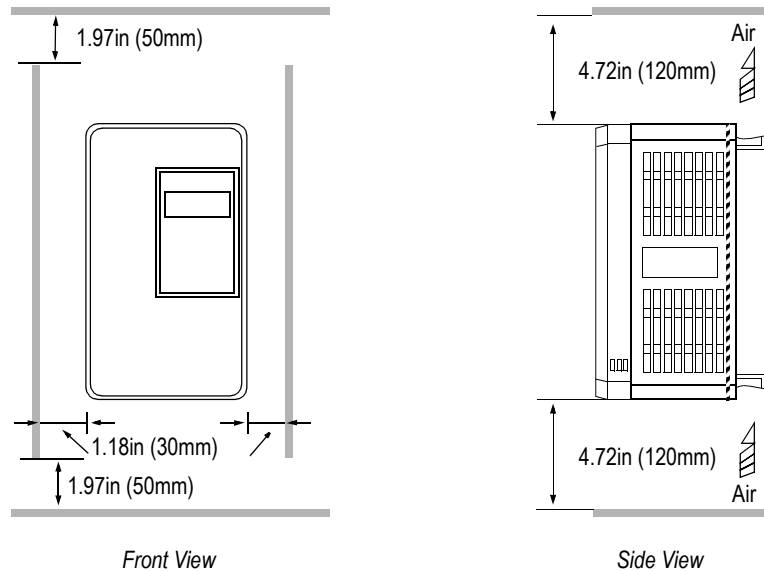

Figure 8 VS-616G5 Clearances

Notes:

- 1) The required clearances at the top, bottom, and both sides of the inverter are the same for both open chassis and NEMA 1 enclosures.
- 2) For inverter models 25HP and less (230V & 460V), and models 20HP and less (575V), remove the top and bottom covers to convert NEMA 1 units to open chassis.
- 3) Allowable intake air temperature:
Open chassis: 14°F to 113°F (-10°C to +45°C)
NEMA 1: 14°F to 104°F (-10°C to 40°C)
- 4) When mounting units in an enclosure, install a fan or other cooling device to limit the air temperature within the inverter to below 113°F (45°C).

1.6 WIRING

CAUTION

PRECAUTIONS

- 1) Do not connect or disconnect wiring, or perform signal checks while the power supply is turned ON.
- 2) Connect the power supply wiring to terminals L1, L2 and L3 on the main circuit input section. DO NOT connect the power supply wiring to output terminals T1, T2 and T3.
- 3) Connect the motor wiring to terminals T1, T2 and T3 on the main circuit output section.
- 4) *Never* touch the output circuit directly or place the output line in contact with the inverter enclosure.
- 5) Do not connect a phase-advancing capacitor or an LC/RC noise filter to the output circuit.
- 6) The motor wiring must be less than 328ft (100m) in length, and it is strongly recommended that it be in a separate conduit from all other wiring.
- 7) Control wiring must be less than 164ft (50m) in length and in a separate conduit from the power wiring.
- 8) Tighten the screws on the main circuit and control circuit terminals.
- 9) Low voltage wires shall be wired with Class 1 wiring.
- 10) Please observe national electrical code (NEC) when wiring electrical devices.

Failure to observe these precautions may result in equipment damage.

Inspection

After wiring is complete, verify that:

- All wiring is correctly installed.
- Excess screws and wire clippings are removed from inside of the unit.
- Screws are securely tightened.
- Exposed wire has no contact with other wiring or terminals.

VS-616G5 Standard Connection Diagram

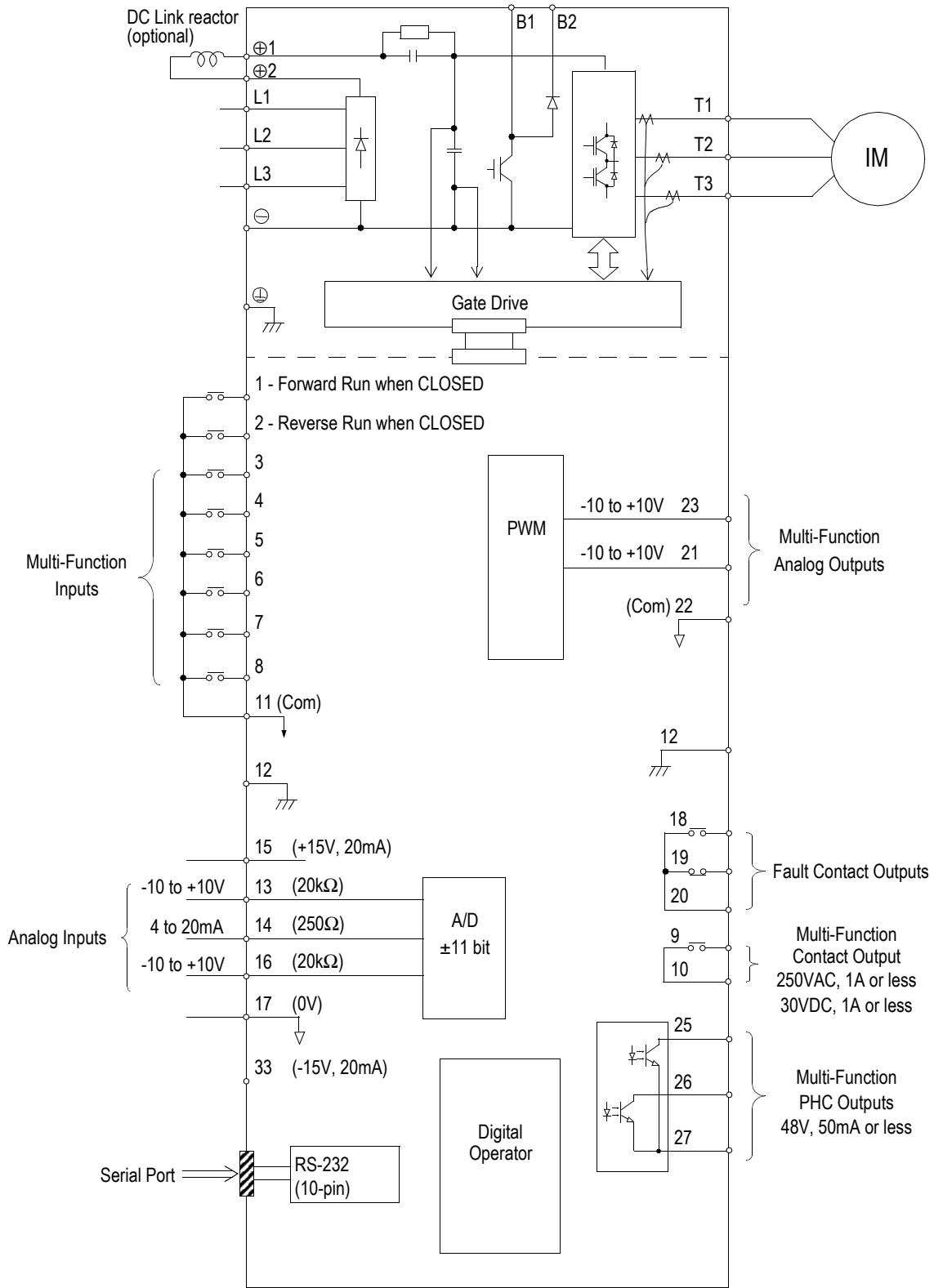

Figure 9 VS-616G5 Terminal Diagram - Model CIMR-G5U4011

VS-616G5 Standard Connection Diagram

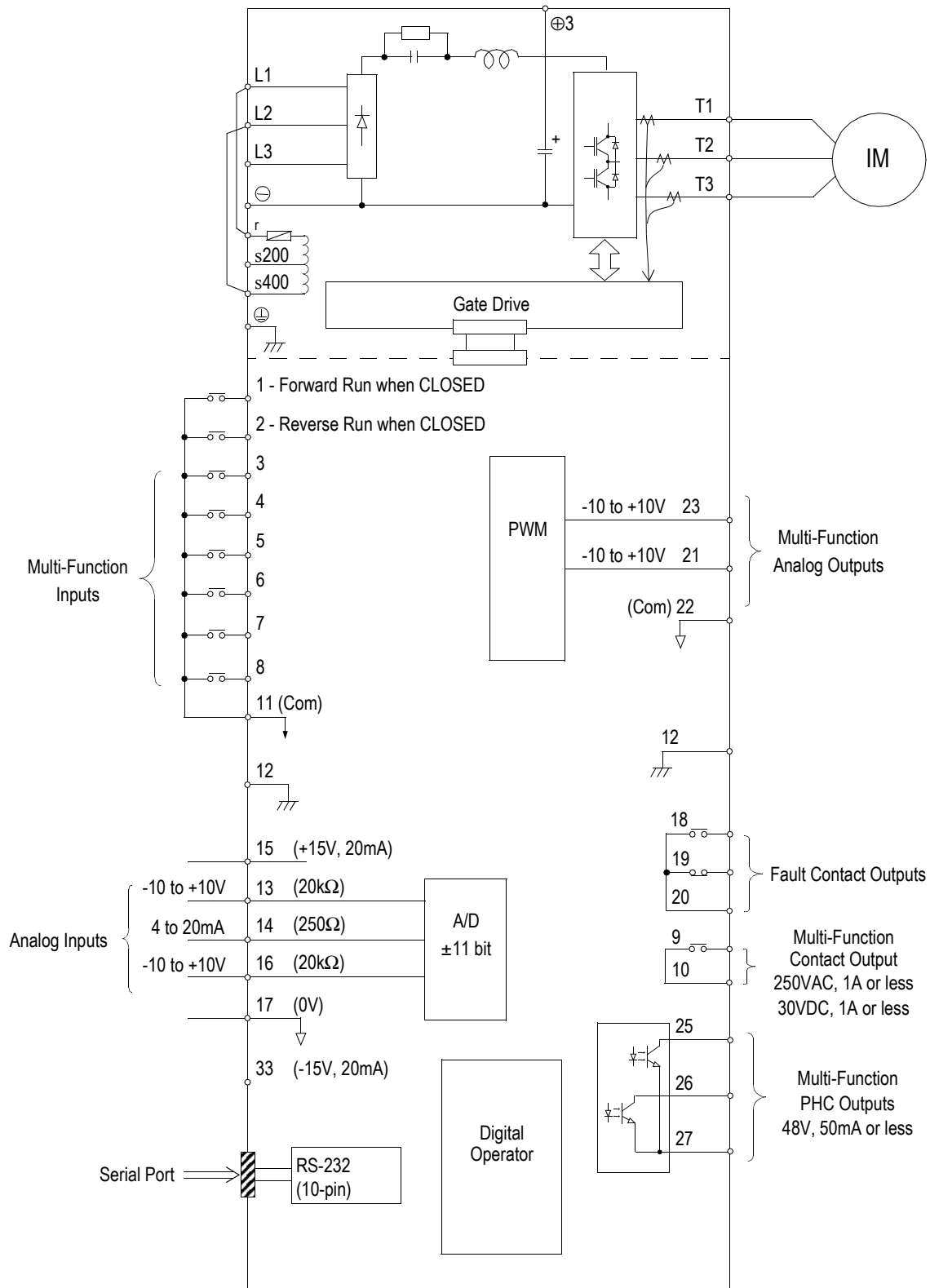

Figure 10 VS-616G5 Terminal Diagram - Model CIMR-G5U4160

VS-616G5 Standard Connection Diagram

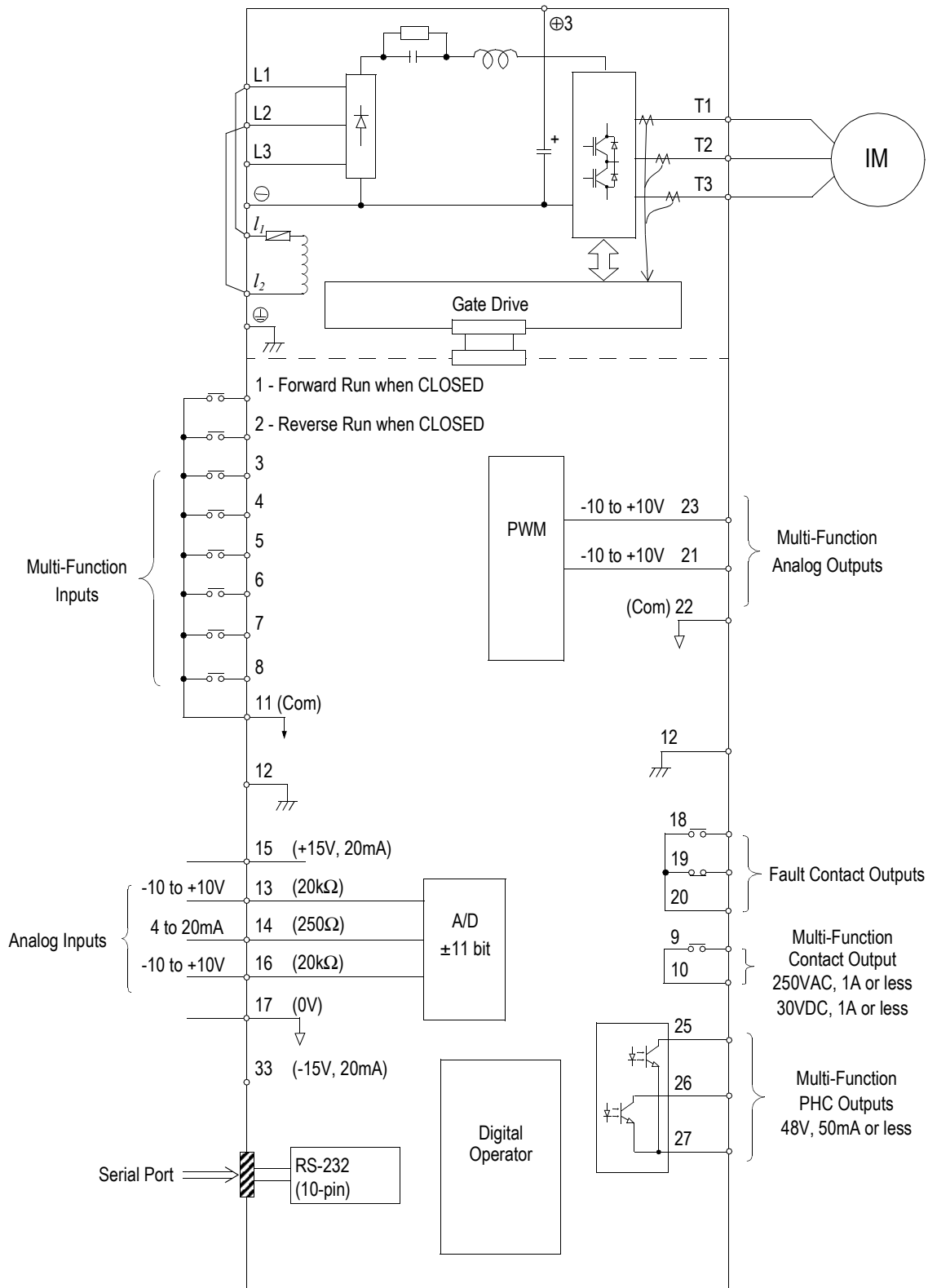
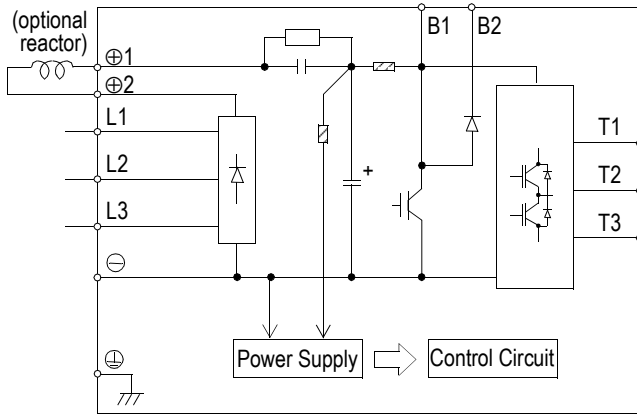

Figure 11 VS-616G5 Terminal Diagram - Model CIMR-G5U5110

Main Circuit Diagrams (230V Class)

CIMR-G5U20P4 to 21P5



CIMR-G5U22P2 to 27P5

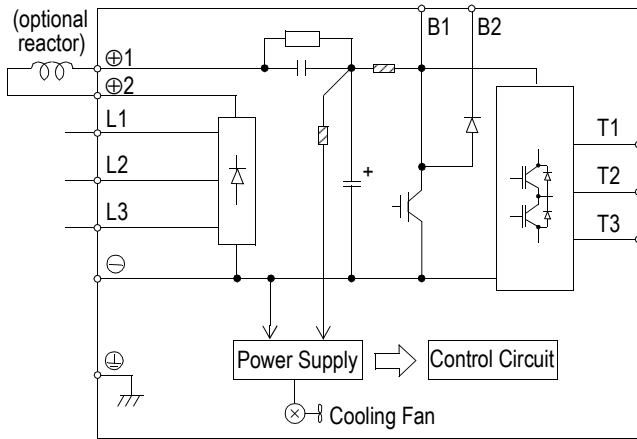

CIMR-G5U2011 to 2015

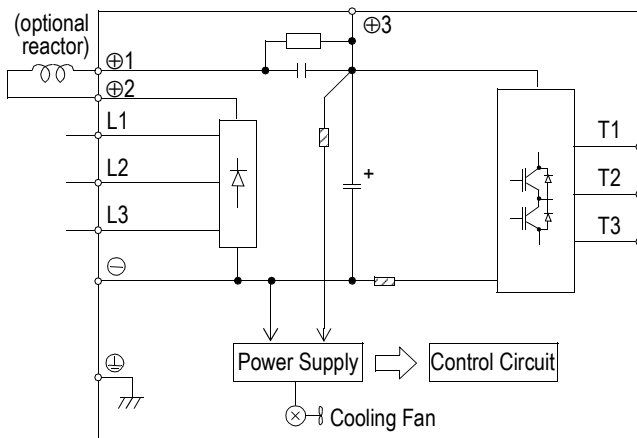

CIMR-G5U2018 to 2022

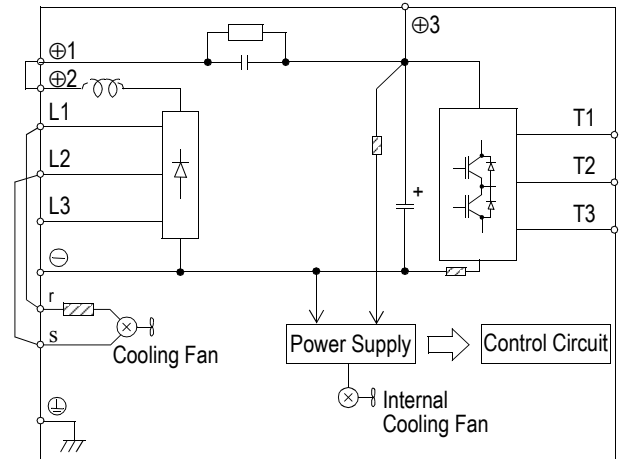

CIMR-G5U2030 to 2075

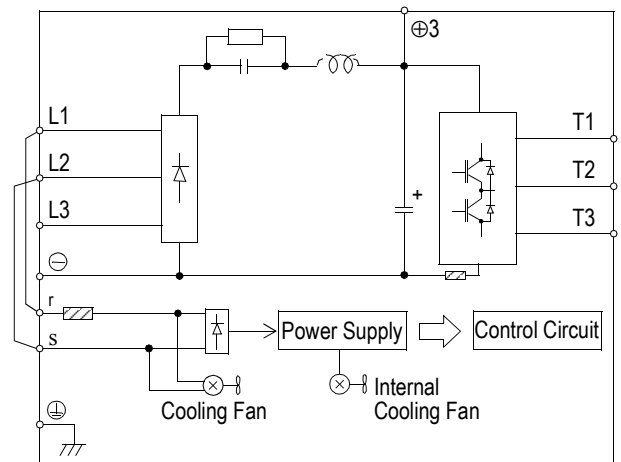

Main Circuit Diagrams (460V Class)
 CIMR-G5U40P4 to 41P5

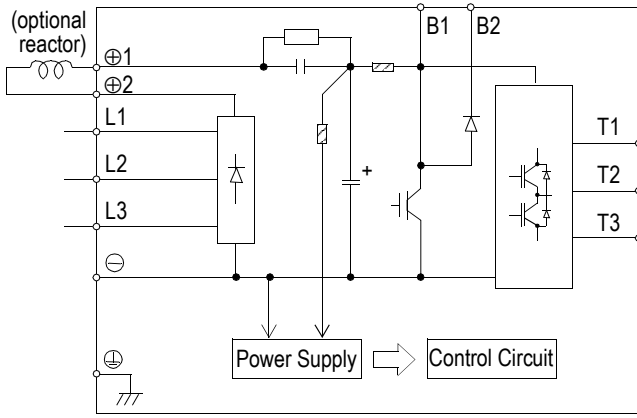

CIMR-G5U42P2 to 4015

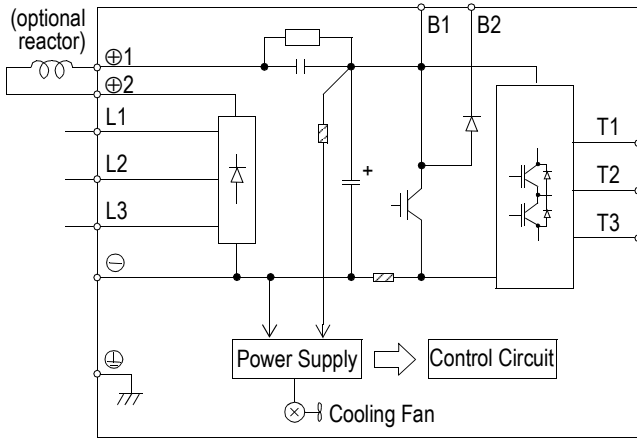

CIMR-G5U4018 to 4045

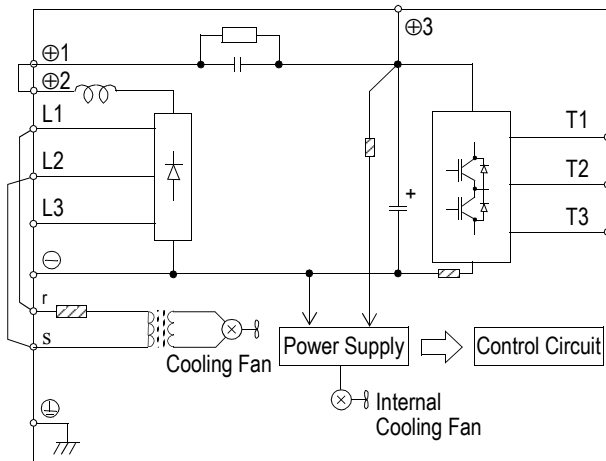

CIMR-G5U4055 to 4160

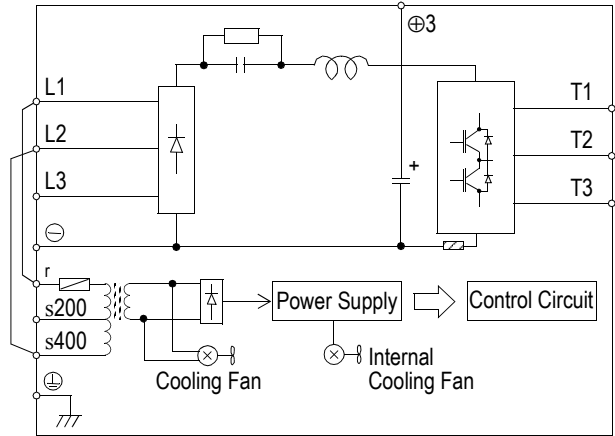

CIMR-G5U4185 to 4300

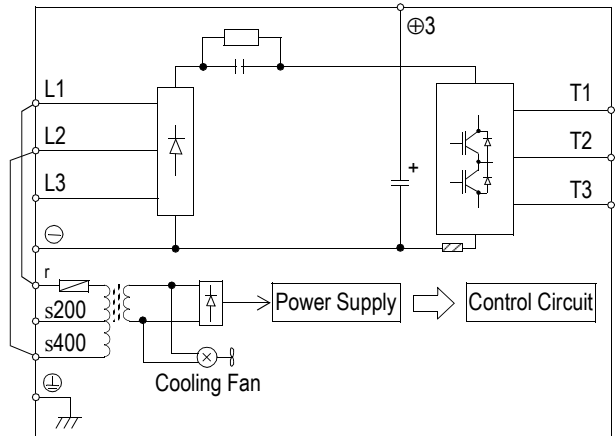

Main Circuit Diagrams (575V Class)

CIMR-G5U51P5

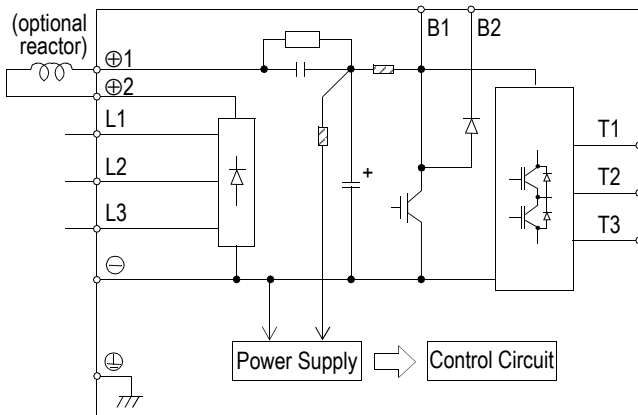

CIMR-G5U5030 to 5160

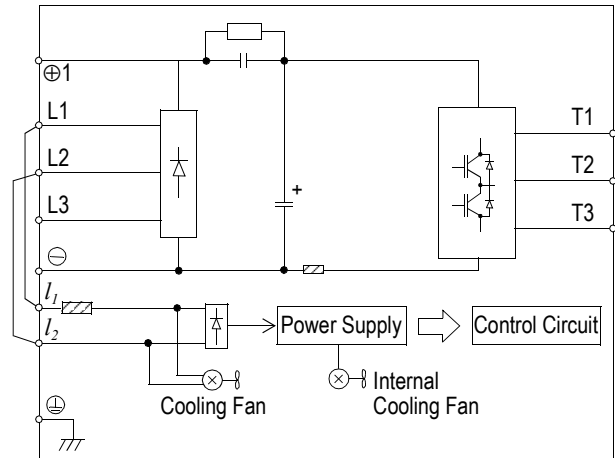

CIMR-G5U52P2 to 5015

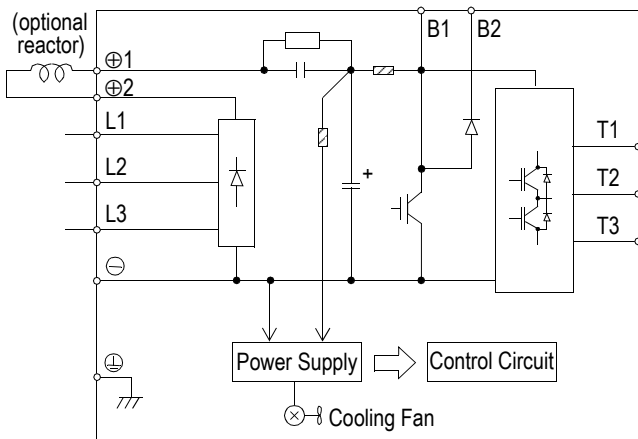

CIMR-G5U5018 to 5022

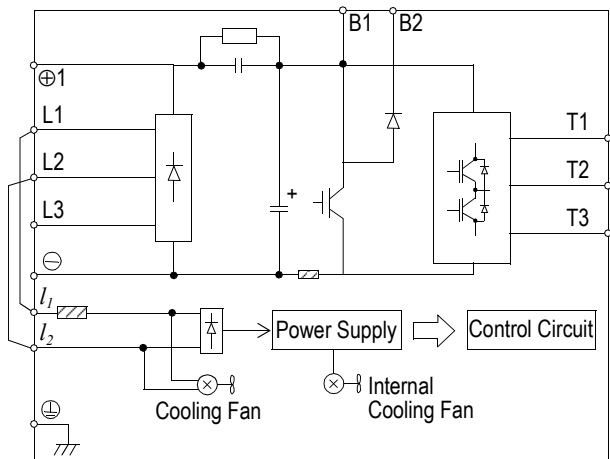

Main Circuit Wiring

Input Wiring

- Molded-Case Circuit Breaker (MCCB)
Be sure to connect MCCBs or fuses between the AC main circuit power supply and VS-616G5 input terminals L1, L2 and L3, to protect the input wiring.
- Ground Fault Interrupter
When connecting a ground fault interrupter to input terminals L1, L2 and L3, select one that is not affected by high frequency.

Examples: NV series by Mitsubishi Electric Co., Ltd. (manufactured in or after 1988), EGSG series by Fuji Electric Co., Ltd. (manufactured in or after 1984).
- Magnetic Contactor (MC)
Inverters can be used without an MC installed on the power supply side. When the main circuit power supply is shut OFF in the sequence, an MC can be used instead of an MCCB. However, when an MC is switched OFF on the primary side, dynamic braking does not function and the motor coasts to stop.

The load can be operated/stopped by opening/closing the MC on the primary side. However, frequent switching may cause the inverter to malfunction.

When using a braking resistor unit, use a sequencer to break the power supply side of the inverter in the event of an overload relay trip contact. If the inverter malfunctions, the braking resistor unit may be burned out.
- Terminal Block Connection Sequence
Input power supply phases can be connected to any terminal regardless of the order of L1, L2 and L3 on the terminal block.
- AC Reactor
When connecting an inverter (230V/460V/575V, 15kW or less) to a large capacity power supply transformer (600kVA or more), or when switching a phase-advancing capacitor, excessive peak current may flow through the input power supply circuit, which may damage the converter section. In such cases, install a DC reactor (optional) between inverter ⊕1 and ⊕2 terminals, or an AC reactor (optional) on the input side. Installation of a reactor is effective for improvement of power factor on the power supply side.
- Surge Suppressor
For inductive loads (i.e. magnetic contactors, magnetic relays, magnetic valves, solenoids, magnetic brakes, etc.) connected near the inverter, use a surge suppressor across the coil to minimize the inductive “kick” when energizing and de-energizing these devices.

Output Wiring

- Motor Connection
Connect motor lead wires to output terminals T1, T2 and T3. Verify that the motor rotates in the forward direction (CCW: counterclockwise when viewed from the motor load side) with the forward run command. If the motor rotation is incorrect, exchange any two of the motor leads.

- Magnetic Starter

Do not connect a magnetic starter or a magnetic contactor to the output circuit. If the motor load is connected or disconnected while the inverter is running, the inverter overcurrent protective circuitry may trip.

- Thermal Overload Relay

An Underwriter’s Laboratory (UL) recognized electronic overload protective function is incorporated into the inverter. However, when driving several motors with one inverter, or when switching between multiple windings of a multiple winding motor, connect an external thermal overload relay. In this case, disable the inverter motor overload feature by setting parameter *LI-01* to “0”.

- Wiring Distance Between Inverter and Motor

If the total wiring distance between inverter and motor is excessively long and the inverter carrier frequency (IGBT switching frequency) is high, harmonic leakage current from the wiring may adversely affect the inverter and peripheral devices. If the wiring distance is long, reduce the inverter carrier frequency as described below. Carrier frequency can be set by parameter *C6-01*. Please note that motor audible noise may increase when lowering the carrier frequency.

Wiring Distance Between Inverter and Motor

Wiring Distance between Inverter and Motor	Up to 164 ft. (50m)	Up to 328 ft. (100m)	More than 328 ft. (100m)
Carrier Frequency (Set value of parameter <i>C6-01</i>)	15kHz or less	10kHz or less	5kHz or less

Grounding

- Ground Resistance

230V class: 100Ω or less, 460V class: 10Ω or less, 575V class: 10Ω or less.

- Never ground the VS-616G5 in common with welding machines, motors, or other high-current electrical equipment. Run all ground wiring in a separate conduit.
- Use ground wiring as specified in “Wire and Terminal Screw Sizes” on page 31, and keep the length as short as possible.
- When using several VS-616G5 units side by side, ground the units as shown in Figure 12, (a) or (b). Do not loop the wires as shown in (c).

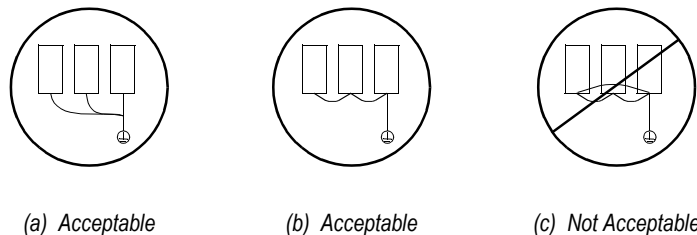

Figure 12 Grounding Example of 3 VS-616G5 Inverters

Terminal Functions

230V Class Terminal Functions

Model CIMR-G5U	20P4 to 27P5	2011 to 2015	2018 to 2022	2030 to 2075
Nominal Motor Output	0.5 to 10HP	15 to 20HP	25 to 30HP	40 to 100HP
L1	Main circuit input power supply			
L2				
L3				
T1	Inverter output			
T2				
T3				
B1	Braking resistor unit	---		
B2				
⊕1	DC reactor (⊕1 - ⊕2) DC power supply (⊕1 -)	DC reactor (⊕1 - ⊕2) DC power supply (⊕1 -) Braking unit (⊕3 -)	DC power supply (⊕1 -) Braking unit (⊕3 -)	Braking unit (⊕3 -) (⊕1 and ⊕2 terminals not provided)
⊕2				
⊕3	---			
r	---		Cooling fan power supply	
s				
Ground terminal (Ground resistance: 100Ω or less)				

460V Class Terminal Functions

Model CIMR-G5U	40P4 to 4015	4018 to 4045	4055 to 4160	4185 to 4300
Nominal Motor Output	0.5 to 25HP	30 to 75HP	100 to 200HP	250 to 500HP
L1	Main circuit input power supply			
L2				
L3				
T1	Inverter output			
T2				
T3				
B1	Braking resistor unit	---		
B2				
⊕1	DC reactor (⊕1 - ⊕2) DC power supply (⊕1 -)	DC power supply (⊕1 -) Braking unit (⊕3 -)	Braking unit (⊕3 -) (⊕1 and ⊕2 terminals not provided)	Braking unit (⊕3 -)
⊕2				
⊕3	---			
s	---		---	
r	---		Cooling fan power supply (Control power supply) r - s 200: 200 to 230 VAC input r - s 400: 380 to 460 VAC input	
s 200				
s 400				
Ground terminal (Ground resistance: 10Ω or less)				

Terminal Functions (continued)

575V Class Terminal Functions

Model CIMR-G5U	51P5 to 5015	5018 to 5022	5030 to 5160
Nominal Motor Output	2.0 to 20HP	25 to 30HP	40 to 200HP
L1	Main circuit input power supply		
L2			
L3			
T1	Inverter output		
T2			
T3			
B1	Braking resistor unit		—
B2			
⊕1	DC reactor (⊕1 - ⊕2) DC power supply (⊕1 -)	DC power supply (⊕1 -)	Braking unit (⊕1 -) DC power supply (⊕1 -)
⊕2			—
I_1	—	Cooling fan and control power supply	
I_2			
Ground terminal (Ground resistance: 10Ω or less)			

Wire and Terminal Screw Sizes

230V Class Wire Size

Circuit	Model CIMR-	Terminal Symbol	Terminal Screw	Wire Size *		Max. Torque lb-in (N·m)	Wire Type
				AWG	mm ²		
Main	G5U20P4	L1, L2, L3, , ⊕1, ⊕2, B1, B2, T1, T2, T3	M4	14 - 10	2 - 5.5	12.4 (1.4)	Power cable: 600V vinyl sheathed wire or equivalent
	G5U20P7	L1, L2, L3, , ⊕1, ⊕2, B1, B2, T1, T2, T3	M4	14 - 10	2 - 5.5	12.4 (1.4)	
	G5U21P5	L1, L2, L3, , ⊕1, ⊕2, B1, B2, T1, T2, T3	M4	14 - 10	2 - 5.5	12.4 (1.4)	
				12 - 10	3.5 - 5.5		
	G5U22P2	L1, L2, L3, , ⊕1, ⊕2, B1, B2, T1, T2, T3	M4	12 - 10	3.5 - 5.5	12.4 (1.4)	
	G5U23P7	L1, L2, L3, , ⊕1, ⊕2, B1, B2, T1, T2, T3	M4	10	5.5	12.4 (1.4)	
	G5U25P5	L1, L2, L3, , ⊕1, ⊕2, B1, B2, T1, T2, T3	M5	8	8	22.1 (2.5)	
				10 - 8	5.5 - 8		
	G5U27P5	L1, L2, L3, , ⊕1, ⊕2, B1, B2, T1, T2, T3	M5	8	8	22.1 (2.5)	
				10 - 8	5.5 - 8		
	G5U2011	L1, L2, L3, , ⊕1, ⊕2, ⊕3, T1, T2, T3	M6	4	22	45.1 (5.1)	
				8	8		
	G5U2015	L1, L2, L3, , ⊕1, ⊕2, ⊕3, T1, T2, T3	M8	3	30	90.3 (10.2)	
			M6	8	8	45.1 (5.1)	
	G5U2018	L1, L2, L3, , ⊕1, ⊕2, ⊕3, T1, T2, T3	M8	3	30	90.3 (10.2)	
				6	14		
	G5U2022	r, s	M4	20 - 10	0.5 - 5.5	12.4 (1.4)	
		L1, L2, L3, , ⊕1, ⊕2, ⊕3, T1, T2, T3					
	G5U2030	L1, L2, L3, T1, T2, T3	M8	4	22	90.3 (10.2)	
		, , ⊕3					
	G5U2037	L1, L2, L3, T1, T2, T3	M10	1/0 x 2P	60 x 2P	203.6 (23.0)	
		, , ⊕3					
	G5U2045	L1, L2, L3, T1, T2, T3	M10	1/0 x 2P	60 x 2P	203.6 (23.0)	
		, , ⊕3					
G5U2055	L1, L2, L3, T1, T2, T3	M10	1/0 x 2P	60 x 2P	203.6 (23.0)		
	, , ⊕3						
G5U2075	L1, L2, L3, T1, T2, T3	M12	4/0 x 2P	100 x 2P	349.6 (39.5)		
	, , ⊕3						
Control	Common to all models	1-33	M3.5	20 - 16	Stranded 0.5 - 1.25 Solid 0.5 - 1.25	-	Twisted shielded wire with Class 1 wiring
		G					

* Wire sizes are based on 75°C copper wire.

Wire and Terminal Screw Sizes

460V Class Wire Size

Circuit	Model CIMR-	Terminal Symbol	Terminal Screw	Wire Size *		Max. Torque lb-in (N·m)	Wire Type	
				AWG	mm ²			
Main	G5U40P4	L1, L2, L3, , ⊕1, ⊕2, B1, B2, T1, T2, T3	M4	14 - 10	2 - 5.5	12.4 (1.4)	Power cable: 600V vinyl sheathed wire or equivalent	
	G5U40P7	L1, L2, L3, , ⊕1, ⊕2, B1, B2, T1, T2, T3	M4	14 - 10 12 - 10	2 - 5.5 3.5 - 5.5	12.4 (1.4)		
	G5U41P5	L1, L2, L3, , ⊕1, ⊕2, B1, B2, T1, T2, T3	M4	14 - 10 12 - 10	2 - 5.5 3.5 - 5.5	12.4 (1.4)		
	G5U42P2	L1, L2, L3, , ⊕1, ⊕2, B1, B2, T1, T2, T3	M4	14 - 10 12 - 10	2 - 5.5 3.5 - 5.5	12.4 (1.4)		
	G5U43P7	L1, L2, L3, , ⊕1, ⊕2, B1, B2, T1, T2, T3	M4	14 - 10 12 - 10	2 - 5.5 3.5 - 5.5	12.4 (1.4)		
	G5U44P0	L1, L2, L3, , ⊕1, ⊕2, B1, B2, T1, T2, T3	M4	12 - 10	3.5 - 5.5	12.4 (1.4)		
	G5U45P5	L1, L2, L3, , ⊕1, ⊕2, B1, B2, T1, T2, T3	M4	12 - 10	3.5 - 5.5	12.4 (1.4)		
	G5U47P5	L1, L2, L3, , ⊕1, ⊕2, B1, B2, T1, T2, T3	M5	8 - 6	8 - 14	22.1 (2.5)		
	G5U4011	L1, L2, L3, , ⊕1, ⊕2, B1, B2, T1, T2, T3	M5 M6	8 - 6 8	8 - 14 8	22.1 (2.5) 45.1 (5.1)		
	G5U4015	L1, L2, L3, , ⊕1, ⊕2, B1, B2, T1, T2, T3	M5 M6	8 - 6 8	8 - 14 8	22.1 (2.5) 45.1 (5.1)		
	G5U4018	L1, L2, L3, , ⊕1, ⊕2, ⊕3, T1, T2, T3	M6 M8	6 8	14 8	45.1 (5.1) 90.3 (10.2)		
	G5U4022	L1, L2, L3, , ⊕1, ⊕2, ⊕3, T1, T2, T3	r, s	M4	20 - 10	0.5 - 5		12.4 (1.4)
				M6	4	22		45.1 (5.1)
				M8	8	8		90.3 (10.2)
	G5U4030	L1, L2, L3, , ⊕1, ⊕2, ⊕3, T1, T2, T3	r, s	M4	20 - 10	0.5 - 5		12.4 (1.4)
				M8	4 8	22 8		90.3 (10.2)
				M8	3 6	30 14		90.3 (10.2)
	G5U4037	L1, L2, L3, , ⊕1, ⊕2, ⊕3, T1, T2, T3	r, s	M4	20 - 10	0.5 - 5		12.4 (1.4)
				M8	1 6	50 14		90.3 (10.2)
				M4	20 - 10	0.5 - 5		12.4 (1.4)
	G5U4045	L1, L2, L3, , ⊕1, ⊕2, ⊕3, T1, T2, T3	r, s	M4	20 - 10	0.5 - 5		12.4 (1.4)
				M8	4 6	22 14		90.3 (10.2)
				M4	20 - 10	0.5 - 5		12.4 (1.4)
	G5U4055	L1, L2, L3, T1, T2, T3 , , ⊕3	r, s200, s400	M10	4/0	100		203.6 (23.0)
				M8	4	22		90.3 (10.2)
				M4	20 - 10	0.5 - 5		12.4 (1.4)
	G5U4075	L1, L2, L3, T1, T2, T3 , , ⊕3	r, s200, s400	M10	1/0 x 2P	60 x 2P		203.6 (23.0)
				M8	4	22		90.3 (10.2)
				M4	20 - 10	0.5 - 5		12.4 (1.4)
	G5U4110	L1, L2, L3, T1, T2, T3 , , ⊕3	r, s200, s400	M10	1/0 x 2P	60 x 2P		203.6 (23.0)
				M8	3	30		90.3 (10.2)
				M4	20 - 10	0.5 - 5		12.4 (1.4)
	G5U4160	L1, L2, L3, T1, T2, T3 , , ⊕3	r, s200, s400	M12	4/0 x 2P	100 x 2P		349.6 (39.5)
				M8	1	50		90.3 (10.2)
				M4	20 - 10	0.5 - 5		12.4 (1.4)
	G5U4185	L1, L2, L3, , ⊕1, ⊕3, T1, T2, T3	r, s200, s400	M16	650MCM x 2P	325 x 2P		867.4 (98.0)
				M8	1	50		90.3 (10.2)
	G5U4220	L1, L2, L3, , ⊕1, ⊕3, T1, T2, T3	r, s200, s400	M4	20 - 10	0.5 - 5.5		12.4 (1.4)
				M16	650MCM x 2P	325 x 2P		867.4 (98.0)
				M8	1/0	60		90.3 (10.2)
G5U4300	L1, L2, L3, , ⊕1, ⊕3, T1, T2, T3	r, s200, s400	M4	20 - 10	0.5 - 5.5	12.4 (1.4)		
			M16	650MCM x 2P	325 x 2P	867.4 (98.0)		
			M8	1/0	60	90.3 (10.2)		
Control	Common to all models	1-33	M3.5	20 - 16	Stranded 0.5 - 1.25	-	Twisted shielded wire with Class 1 wiring	
		G	M3.5	20 - 14	Solid 0.5 - 1.25	8.9 (1.0)		

* Wire sizes are based on 75°C copper wire.

Wire and Terminal Screw Sizes (continued)

575V Class Wire Size

Circuit	Model CIMR-	Terminal Symbol	Terminal Screw	Wire Size *		Max. Torque lb-in (N-m)	Wire Type
				AWG	mm ²		
Main	G5U51P5 G5U52P2	L1, L2, L3, , ⊕1, ⊕2, B1, B2, T1, T2, T3	M4	14 - 10	2 - 5.5	12.4 (1.4)	Power cable: 600V vinyl sheathed wire or equivalent
	G5U53P7	L1, L2, L3, , ⊕1, ⊕2, B1, B2, T1, T2, T3	M4	14 - 10 12 - 10	2 - 5.5 3.5 - 5.5	12.4 (1.4)	
	G5U55P5	L1, L2, L3, , ⊕1, ⊕2, B1, B2, T1, T2, T3	M4	12 - 10	3.5 - 5.5	12.4 (1.4)	
	G5U57P5	L1, L2, L3, , ⊕1, ⊕2, B1, B2, T1, T2, T3	M4	10 12 - 10	5.5 3.5 - 5.5	12.4 (1.4)	
	G5U5011	L1, L2, L3, , ⊕1, ⊕2, B1, B2, T1, T2, T3	M5 M6	10 - 6	5.5 - 14	12.4 (1.4) 45.1 (5.1)	
	G5U5015	L1, L2, L3, , ⊕1, ⊕2, B1, B2, T1, T2, T3	M5 M6	8 - 6 10 - 6	8 - 14 5.5 - 14	22.1 (2.5) 45.1 (5.1)	
	G5U5018 G5U5022	L1, L2, L3, , ⊕1, B1, B2, T1, T2, T3	M6 †	8 - 6 10 - 6	8 - 14 5.5 - 14	45.1 (5.1) 20 (2.3)	
	G5U5030	l_1, l_2 L1, L2, L3, , ⊕1, T1, T2, T3	M4 M8	14 - 10 6 - 1/0	2 - 5.5 14 - 50	12.4 (1.4) 90.3 (10.3)	
		l_1, l_2	†	8 - 2	8 - 30	20 (2.3)	
	G5U5037	L1, L2, L3, , ⊕1, T1, T2, T3	M8 †	4 - 1/0 8 - 2	22 - 50 8 - 30	90.3 (10.3) 20 (2.3)	
		l_1, l_2	M4	14 - 10	2 - 5.5	12.4 (1.4)	
	G5U5045	L1, L2, L3, , ⊕1, T1, T2, T3	M8 †	3 - 1/0 8 - 2	30 - 50 8 - 30	90.3 (10.3) 20 (2.3)	
		l_1, l_2	M4	14 - 10	2 - 5.5	12.4 (1.4)	
	G5U5055	L1, L2, L3, , ⊕1, T1, T2, T3	M8 †	2 - 1/0 6 - 2	30 - 50 22 - 30	90.3 (10.3) 20 (2.3)	
		l_1, l_2	M4	14 - 10	2 - 5.5	12.4 (1.4)	
	G5U5075	L1, L2, L3, , ⊕1, T1, T2, T3	M8 †	2/0 - 1/0 4 - 2	50 - 60 22 - 30	90.3 (10.3) 20 (2.3)	
		l_1, l_2	M4	14 - 10	2 - 5.5	12.4 (1.4)	
	G5U5090	L1, L2, L3, , ⊕1, T1, T2, T3	M10 †	3/0 - 300 4 - 2/0	80 - 150 22 - 60	203.6 (23) 20 (2.3)	
		l_1, l_2	M4	14 - 10	2 - 5.5	12.4 (1.4)	
	G5U5110	L1, L2, L3, , ⊕1, T1, T2, T3	M12 †	300-400 4 - 2/0	150 - 200 22 - 60	349.6 (39.5) 20 (2.3)	
		l_1, l_2	M4	14 - 10	2 - 5.5	12.4 (1.4)	
	G5U5160	L1, L2, L3, , ⊕1, T1, T2, T3	M12 †	350-400 3 - 2/0	180 - 200 30 - 60	349.6 (39.5) 20 (2.3)	
		l_1, l_2	M4	14 - 10	2 - 5.5	12.4 (1.4)	
	Control	Common to all models	1-33	M3.5	20 - 16	Stranded 0.5 - 1.25	
	G			20 - 14	Solid 0.5 - 1.25	8.9 (1.0)	

* Wire sizes are based on 75°C copper wire. † Indicates terminal uses a pressure lug.

Wire and Terminal Screw Sizes (continued)

JST Closed Loop Connectors

Wire Size *		Terminal Screw	JST Closed-Loop Connectors (Lugs)	Max. Torque lb-in (N·m)
AWG	mm ²			
20	0.5	M3.5	1.25 - 3.5	8.9 (1.0)
		M4	1.25 - 4	12.4 (1.4)
18	0.75	M3.5	1.25 - 3.5	8.9 (1.0)
		M4	1.25 - 4	12.4 (1.4)
16	1.25	M3.5	1.25 - 3.5	8.9 (1.0)
		M4	1.25 - 4	12.4 (1.4)
14	2	M3.5	2 - 3.5	8.9 (1.0)
		M4	2 - 4	12.4 (1.4)
		M5	2 - 5	22.1 (2.5)
		M6	2 - 6	45.1 (5.1)
		M8	2 - 8	90.3 (10.2)
12 - 10	3.5 - 5.5	M4	5.5 - 4	12.4 (1.4)
		M5	5.5 - 5	22.1 (2.5)
		M6	5.5 - 6	45.1 (5.1)
		M8	5.5 - 8	90.3 (10.2)
8	8	M5	8 - 5	22.1 (2.5)
		M6	8 - 6	45.1 (5.1)
		M8	8 - 8	90.3 (10.2)
6	14	M6	14 - 6	45.1 (5.1)
		M8	14 - 8	90.3 (10.2)
4	22	M6	22 - 6	45.1 (5.1)
		M8	22 - 8	90.3 (10.2)
3 - 2	30 - 38	M8	38 - 8	90.3 (10.2)
1 - 1/0	50 - 60	M8	60 - 8	90.3 (10.2)
		M10	60 - 10	203.6 (23.0)
3/0	80	M10	80 - 10	203.6 (23.0)
4/0	100		100 - 10	203.6 (23.0)
4/0	100	M12	100 - 12	349.6 (39.5)
300MCM	150		150 - 12	349.6 (39.5)
400MCM	200		200 - 12	349.6 (39.5)
650MCM	325	M12 x 2	325 - 12	349.6 (39.5)
		M16	325 - 16	867.4 (98.0)

Note 1:

The use of a JST closed-loop connector (lug) is recommended to maintain proper clearances. Please contact your Yaskawa representative for more information.

Note 2:

Voltage drop should be considered when determining wire size. Voltage drop can be calculated using the following equation:

$$\begin{aligned} &\text{Phase-to phase voltage drop (V)} \\ &= \sqrt{3} \text{ wire resistance } (\Omega/\text{km}) \times \text{wiring distance (m)} \times \text{current (A)} \times 10^{-3} \end{aligned}$$

Select a wire size so that voltage drop will be less than 2% of the normal rated voltage.

Control Circuit Wiring

The table below outlines the functions of the control circuit terminals.

Control Circuit Terminals

Classification	Terminal	Signal Function	Description	Signal Level	
Sequence Input Signal	1	Forward run/stop	Forward run when closed, stop when open (2-wire configuration)	Photo-coupler insulated Input: +24VDC, 8mA	
	2	Reverse run/stop	Reverse run when closed, stop when open (2-wire configuration)		
	3	External fault input	Fault when closed, normal state when open		Multi-function contact inputs (H1-01 to H1-06)
	4	Fault reset input	Reset when closed		
	5	Master/Aux. change Multi-step speed ref.1)	Aux. freq. ref. when closed		
	6	Multi-step speed ref.2	Effective when closed		
	7	Jog reference	Jog run when closed		
	8	External baseblock	Inv. output baseblocked when closed		
	11	Sequence control input common terminal	—		
Analog Input Signal	15	+15V Power supply output	For analog command +15V power supply	+15V (Allowable current 20mA max.)	
	33	-15V Power supply output	For analog command -15V power supply	-15V (Allowable current 20mA max.)	
	13	Master frequency ref. (voltage)	-10 to +10V/-100% to +100% 0 to +10V/100%	-10 to +10V (20kΩ), 0 to +10V/(20kΩ)	
	14	Master frequency ref. (current)	4 to 20mA/100%. Multi-function analog input (H3-08, H3-09, H3-10, H3-11)	4 to 20mA (250Ω)	
	16	Multi-function analog input	-10 to +10V/-100% to +100% 0 to +10 V/100% Multi-function analog input (H3-04, H3-05, H3-06, H3-07)	-10 to +10V (20kΩ), 0 to +10V/(20kΩ)	
	17	Common terminal for control circuit	0V	—	
	12	Connection to shield sheath of signal lead	—	—	
Sequence Output Signal	9	During running (NO contact)	Closed when running	Multi-function output (H2-01 to H2-03)	Dry contact Contact capacity: 250VAC, 1A or less 30VDC, 1A or less
	10				
	25	Zero speed detection	Activates at min. freq. (E1-09) or less	Open collector output 48V, 50mA or less	
	26	Speed agree detection	Activates when the freq. reaches to ±1Hz of set freq.		
	27	Open collector output common	—	—	
	18	Fault contact output (NO/NC contact)	When faulted closed between terminals 18 and 20 When faulted open between terminals 19 and 20	Multi-function output (H2-01 to H2-03)	Dry contact Contact capacity: 250VAC, 1A or less 30VDC, 1A or less
	19				
20					
Analog Output Signal	21	Frequency meter output	0 to ±10V/100% frequency	Multi-function analog monitor 1 (H4-01, H4-02, H4-03)	0 to ±11V Max. ±5% 2mA or less
	22	Common			
	23	Current monitor	5V/inverter rated current	Multi-function analog monitor 2 (H4-04, H4-05, H4-06)	—

11	12 (G)	13	14	15	16	17	25	26	27	33	18	19	20
1	2	3	4	5	6	7	8	21	22	23	9	10	

Figure 13 Control Circuit Terminal Arrangement

This page intentionally left blank.



- CHAPTER 2 -

OPERATION

<u>Section</u>	<u>Description</u>	<u>Page</u>
2	OPERATION	
	Precautions	38
2.1	TRIAL OPERATION	39
	Digital Operator Display at Power-up	39
	Operation Checkpoints	40
	Operation by Digital Operator	40
	Operation by Control Circuit Terminal Signal	42
2.2	DIGITAL OPERATOR DISPLAY	43
2.3	OPERATION MODE SELECTION	44

WARNING

PRECAUTIONS

- 1) Only turn ON the input power supply after replacing the front cover. Do not remove the cover while the inverter is powered up.
- 2) When the retry function (parameter *L5-02*) is selected, do not approach the inverter or the load, since it may restart suddenly after being stopped.
- 3) Since the Stop key can be disabled by a function setting, install a separate emergency stop switch to remove input power from the inverter.
- 4) Do not touch the heatsink or braking resistor, due to very high temperatures.
- 5) Since it is very easy to change operation speed from low to high speed, verify the safe working range of the motor and machine before operation. Also, verify the parameter settings prior to operation.
- 6) Install a separate holding brake, if necessary.
- 7) Do not check signals during operation.
- 8) All inverter parameters have been preset at the factory. Do not change the settings unless it is required.

Failure to observe these precautions may result in equipment damage, serious personal injury or death.

2.1 TRIAL OPERATION

To ensure safety, prior to initial operation, disconnect the machine coupling so that the motor is isolated from the machine. If initial operation must be performed while the motor is still coupled to the machine, use great care to avoid potentially hazardous conditions. Check the following items before a trial run:

- Wiring and terminal connections are proper.
- Wire clippings and other debris removed from the unit.
- Screws are securely tightened.
- Motor is securely mounted.
- All items are correctly grounded.

Digital Operator Display at Power-Up

When the system is ready for operation, turn ON the power supply. Verify that the inverter powers up properly. If any problems are detected, turn OFF the power supply immediately. The digital operator display illuminates as shown below when the power supply is turned ON.

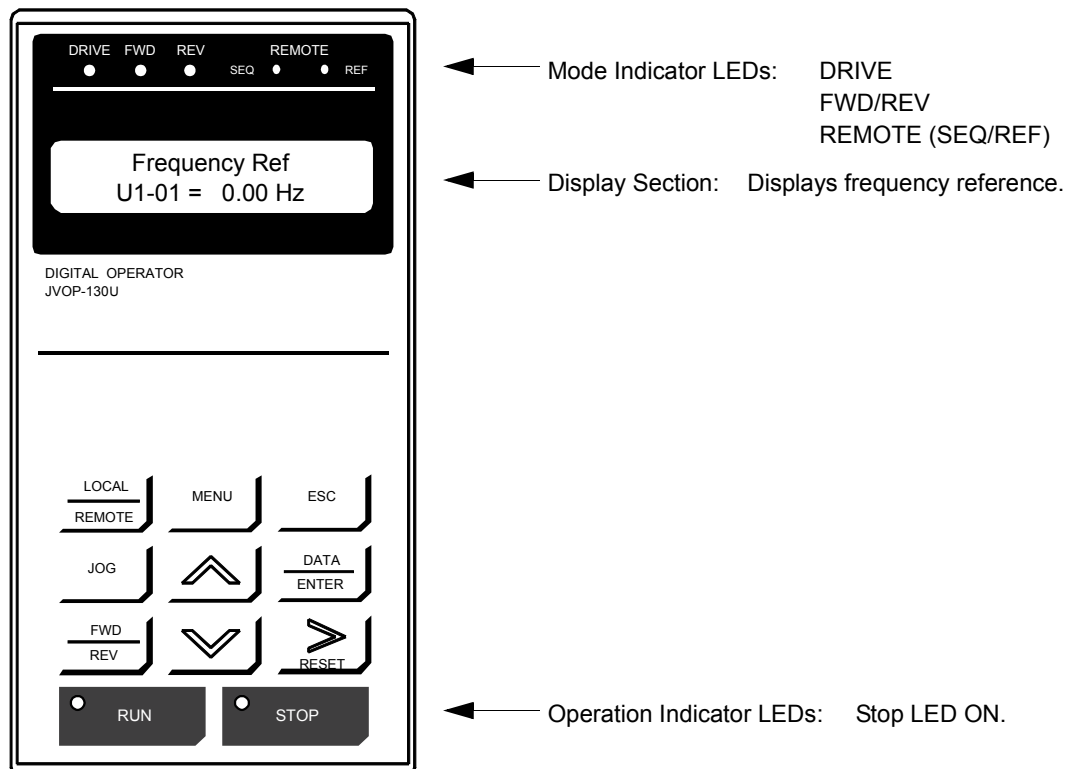

Figure 14 Digital Operator Display at Power-up

Operation Checkpoints:

- Motor rotates smoothly.
- Motor rotates in the correct direction.
- Motor has no abnormal vibration nor noise.
- Acceleration and deceleration are smooth.
- Unit is not overloaded.
- Status indicator LEDs and digital operator display are correct.

Operation by Digital Operator

The diagram below shows a typical operation profile using the digital operator.

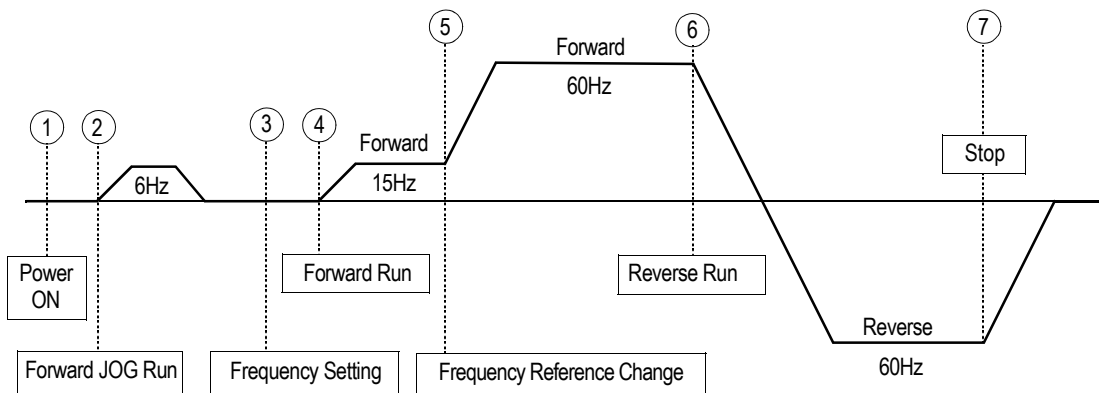

















Figure 15 Operation Sequence by Digital Operator

Typical Operation Example by Digital Operator

Description	Key Sequence	Digital Operator Display
<p>① Power ON</p> <ul style="list-style-type: none"> · Displays frequency reference value. 		<div style="border: 1px solid black; padding: 5px; width: fit-content; margin: 0 auto;"> Frequency Ref U1-01 = 0.00 Hz </div>
<p>Operation Condition Setting</p> <ul style="list-style-type: none"> · Select LOCAL mode. 		REMOTE LED (SEQ, REF) OFF
<p>② Forward Jog Run (6Hz)</p> <ul style="list-style-type: none"> · JOG run procedure (Runs while depressing JOG key.) 		
<p>③ Frequency Setting</p> <ul style="list-style-type: none"> · Change frequency reference value. Digit to be changed blinks. · Write-in set value. · Select output frequency monitor display. 	 <p>Change the value by depressing</p>    	<div style="border: 1px solid black; padding: 5px; width: fit-content; margin: 0 auto;"> Frequency Ref 0 00.00 Hz </div> <div style="border: 1px solid black; padding: 5px; width: fit-content; margin: 0 auto;"> Frequency Ref 01 5 .00 Hz </div> <div style="border: 1px solid black; padding: 5px; width: fit-content; margin: 0 auto;"> Entry Accepted </div> <div style="border: 1px solid black; padding: 5px; width: fit-content; margin: 0 auto;"> Frequency Ref 01 5 .00 Hz </div> <div style="border: 1px solid black; padding: 5px; width: fit-content; margin: 0 auto;"> Output Freq U1-02 = 0.00 Hz </div>
<p>④ Forward Run</p> <ul style="list-style-type: none"> · Forward run (15Hz) Run & FWD LEDs light. 		<div style="border: 1px solid black; padding: 5px; width: fit-content; margin: 0 auto;"> Output Freq U1-02 = 15.00 Hz </div>
<p>⑤ Frequency Reference Value Change (15~60Hz)</p> <ul style="list-style-type: none"> · Select frequency reference value display · Change set value. · Write-in set value. · Select output frequency monitor display. 	  <p>Depress twice.</p> <p>Change the value by depressing</p>    	<div style="border: 1px solid black; padding: 5px; width: fit-content; margin: 0 auto;"> Frequency Ref 0 15.00 Hz </div> <div style="border: 1px solid black; padding: 5px; width: fit-content; margin: 0 auto;"> Frequency Ref 06 0 .00 Hz </div> <div style="border: 1px solid black; padding: 5px; width: fit-content; margin: 0 auto;"> Entry Accepted </div> <div style="border: 1px solid black; padding: 5px; width: fit-content; margin: 0 auto;"> Output Freq U1-02 = 60.00 Hz </div>
<p>⑥ Reverse Run</p> <ul style="list-style-type: none"> · Select reverse run. REV LED lights. 		<div style="border: 1px solid black; padding: 5px; width: fit-content; margin: 0 auto;"> Output Freq U1-02 = -60.00 Hz </div>
<p>⑦ Stop</p> <ul style="list-style-type: none"> · Decelerates to stop. Stop LED lights. 		<div style="border: 1px solid black; padding: 5px; width: fit-content; margin: 0 auto;"> Output Freq U1-02 = 0.00 Hz </div>

Operation by Control Circuit Terminal Signal

The diagram below shows a typical operation profile using the control circuit terminal signals.

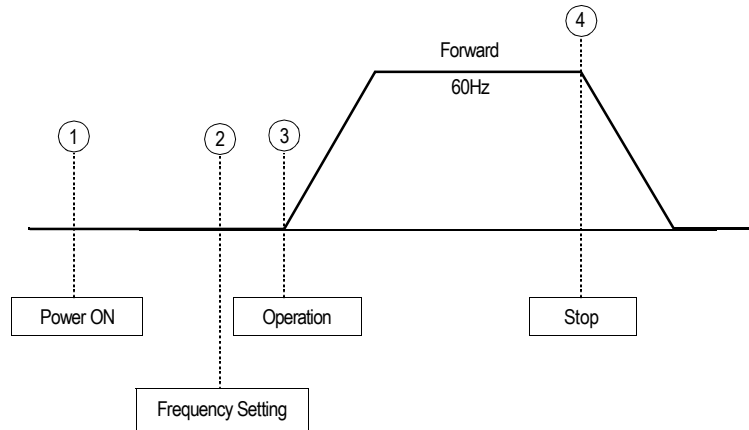





Figure 16 Operation Sequence by Control Circuit Terminal Signal

Typical Operation Example by Control Circuit Terminal Signal

Description	Key Sequence	Digital Operator Display
<p>① Power ON</p> <ul style="list-style-type: none"> · Displays frequency reference value. REMOTE mode is preset at the factory. 		<div style="border: 1px solid black; padding: 5px; margin-bottom: 5px;"> Frequency Ref U1-01 = 0.00 Hz </div> REMOTE LED (SEQ, REF) ON
<p>Output Frequency Display</p> <ul style="list-style-type: none"> · Switch to output frequency display. 		<div style="border: 1px solid black; padding: 5px; margin-bottom: 5px;"> Output Freq U1-02 = 0.00 Hz </div>
<p>Forward Jog Run (6Hz)</p> <ul style="list-style-type: none"> · Close between control circuit terminals 1 & 11, and 7 & 11 closed to perform JOG run. Run & FWD LEDs illuminate. · Open between terminals 1 & 11, and 7 & 11 after verifying JOG operation 		<div style="border: 1px solid black; padding: 5px; margin-bottom: 5px;"> Output Freq U1-02 = 6.00 Hz </div>
<p>② Frequency Setting</p> <ul style="list-style-type: none"> · Input frequency reference via terminal 13 (voltage) or 14 (voltage/current) and verify the input value with the digital operator. 		<div style="border: 1px solid black; padding: 5px; margin-bottom: 5px;"> Frequency Ref U1-01 = 60.00 Hz </div>
<p>Output Frequency Display</p> <ul style="list-style-type: none"> · Select output frequency monitor display. 		<div style="border: 1px solid black; padding: 5px; margin-bottom: 5px;"> Output Freq U1-02 = 0.00 Hz </div>
<p>③ Forward Run</p> <ul style="list-style-type: none"> · Close between terminals 1 & 11 to perform forward run. 		<div style="border: 1px solid black; padding: 5px; margin-bottom: 5px;"> Output Freq U1-02 = 60.00 Hz </div>
<p>④ Stop</p> <ul style="list-style-type: none"> · Open between terminals 1 & 11 to stop operation. Stop LED illuminates. 		<div style="border: 1px solid black; padding: 5px; margin-bottom: 5px;"> Output Freq U1-02 = 0.00 Hz </div>

2.2 DIGITAL OPERATOR DISPLAY

All functions of the VS-616G5 are accessed using the digital operator. Below are descriptions of the display and keypad sections.

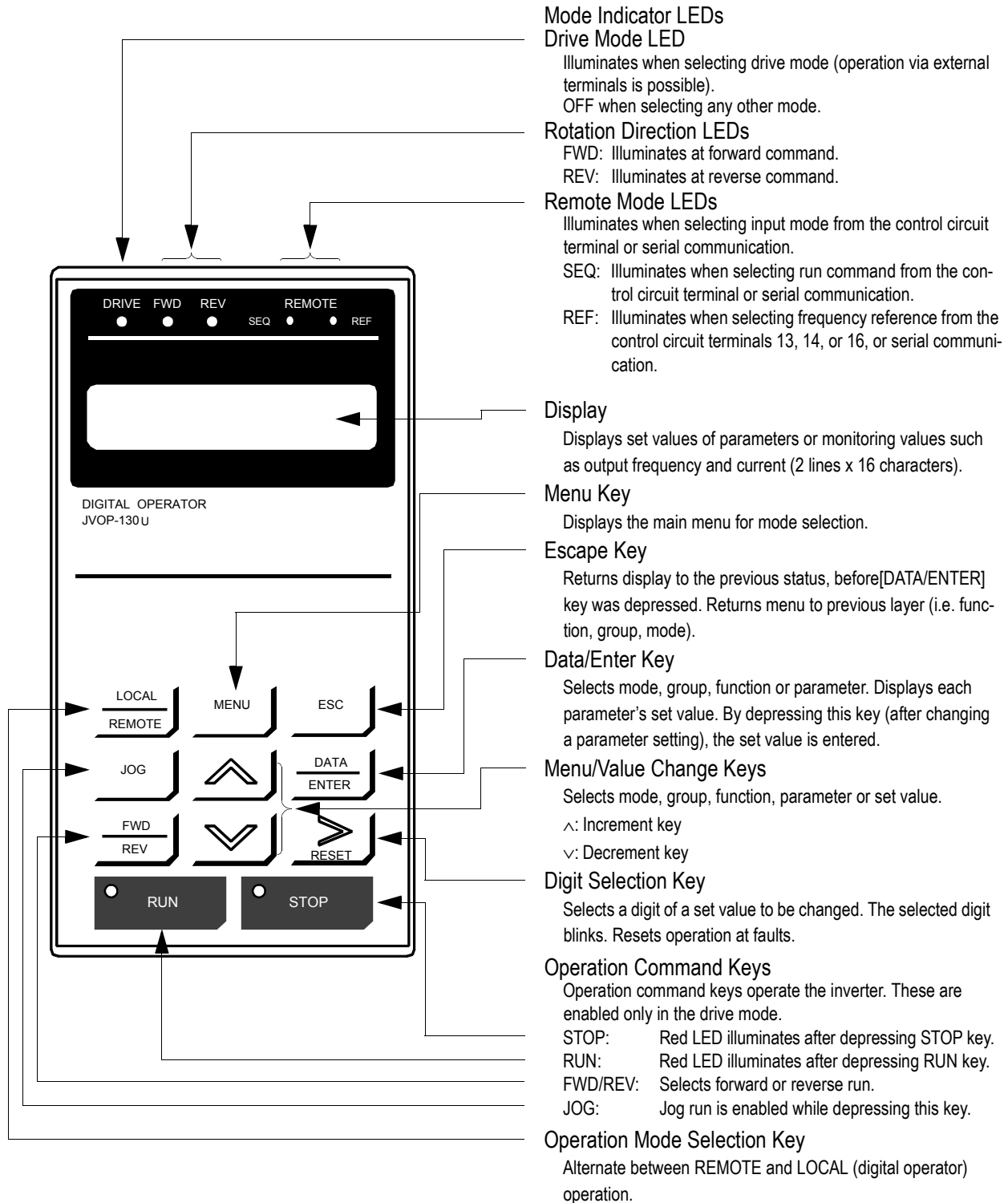

Figure 17 Digital Operator Display at Power-up

2.3 OPERATION MODE SELECTION

The VS-616G5 has two operation modes: LOCAL and REMOTE (see table below for description). These two modes can be selected by the digital operator “LOCAL/REMOTE” key or a multi-function input terminal command only when operation is stopped. The operation mode selected can be verified by observing the SEQ and REF LEDs on the digital operator (as shown below). The operation mode is set to REMOTE (run by control circuit terminals 13 and/or 14 frequency reference and run command from control circuit terminals) prior to shipment. Multi-function contact inputs from control circuit terminals 3 to 8 are enabled in both operation modes.

- LOCAL: Both frequency reference and run command are set by the digital operator. SEQ and REF LEDs go OFF.
- REMOTE: Master frequency reference and run command can be selected as described in the table below.

Operation Mode Selection

Setting	Reference Selection (B1-01)	REF LED	Operation Method Selection (B1-02)	SEQ LED
0	Master frequency reference from digital operator	OFF	Operation by run command from digital operator	OFF
1	Master frequency reference from control circuit terminals 13 and 14	ON	Operation by run command from control circuit terminal	ON
2	Master frequency reference set by serial communication	blinking	Operation by run command from serial communication	blinking
3	Master frequency reference set by option card	blinking	Operation by run command from option card	blinking
4	Master frequency reference set by EWS (Engineering Work Station). This setting will be used with the CP-717 <1110>.	ON	Operation by run command from EWS (CP-717) <1110>.	ON

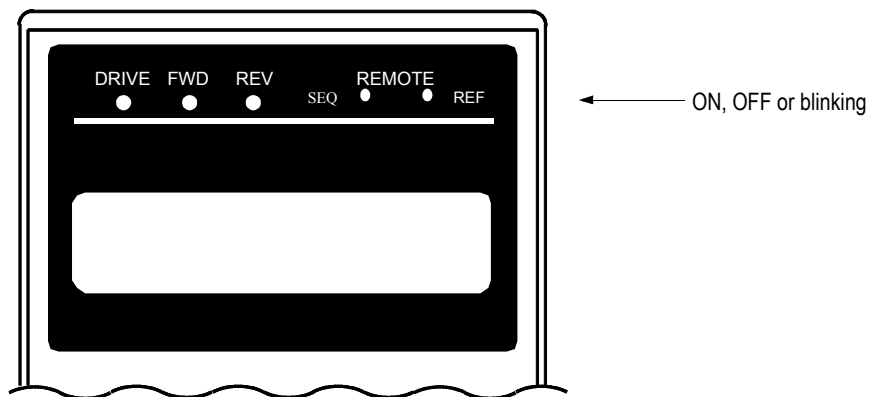

Figure 18 Operation Mode LEDs

- CHAPTER 3 -

QUICK-START PROGRAMMING

<u>Section</u>	<u>Description</u>	<u>Page</u>
3	QUICK-START PROGRAMMING	
	Quick-Start Parameter Sequence	46
3.1	MAIN MENU: INITIALIZE	47
3.2	MAIN MENU: PROGRAMMING	48
3.3	MAIN MENU: AUTO-TUNING	59

Quick-Start Parameter Sequence

Main Menu *	Key Press	Function	Parameter No.
Operation		Frequency Reference	U1-01
	^	Output Frequency	U1-02
	^	Output Current	U1-03
	^	Output Voltage	U1-06
	^ DATA/ENTER	U2 Fault Trace U2-01 to U2-14	U2
	^ DATA/ENTER	U3 Fault History U3-01 to U3-08	U3
	^ DATA/ENTER	U1 Monitor U1-01 to U1-14	U1
Initialize	ESC, ^, DATA/ENTER	Select Language	A1-00
	^	Access Level	A1-01
	^	Control Method	A1-02
	^	Initialize Parameters	A1-03
	^	Enter Password	A1-04
Programming	ESC, ^, ^, DATA/ENTER	Reference Source	B1-01
	^	Run Source	B1-02
	^	Stopping Method	B1-03
	^	Acceleration Time 1	C1-01
	^	Deceleration Time 1	C1-02
	^	Preset Frequency Reference 1	D1-01
	^	Preset Frequency Reference 2	D1-02
	^	Preset Frequency Reference 3	D1-03
	^	Preset Frequency Reference 4	D1-04
	^	Jog Frequency Reference	D1-09
	^	Input Voltage	E1-01
	^	Motor Selection	E1-02
	^	V/f Pattern Selection	E1-03
	^	Maximum Frequency	E1-04
	^	Maximum Voltage	E1-05
	^	Maximum Voltage Output Frequency	E1-06
	^	Middle Output Frequency	E1-07
	^	Middle Output Voltage	E1-08
	^	Minimum Output Frequency	E1-09
	^	Minimum Output Voltage	E1-10
	^	Base Voltage	E1-13
	^	Motor Rated Current	E2-01
	^	Motor Rated Slip Frequency	E2-02
	^	Motor No-Load Current	E2-03
^	Number of Motor Poles	E2-04	
Auto-Tuning	ESC, ^, ^, ^, DATA/ENTER	Rated Voltage	--
	^	Rated Current	--
	^	Rated Frequency	--
	^	Rated Speed	--
	^	Number of Poles	--
Modified Constants	ESC, ^, ^, ^, ^, DATA/ENTER		

* Depress the Menu key on the digital operator to return to **Main Menu: Operation.**

The VS-616G5 ships preset to open loop vector control, quick-start access level. Included in this section are descriptions of the Quick-Start parameters, for simplified operation of this drive.

3.1 Main Menu: Initialize <ENTER>

A1-00 Language Selection

Select Language

V/f Control	V/f w/ PG	Open Loop Vector	Flux Vector
√	√	√	√

The standard G5 software incorporates seven display languages. Select the language displayed on the digital operator according to the following table:

Setting	Description
0	English (<i>factory default</i>)
1	Japanese
2	German <1110>
3	French <1110>
4	Italian <1110>
5	Spanish <1110>
6	Portuguese

A1-01 Parameter Access Level

Access Level

V/f Control	V/f w/ PG	Open Loop Vector	Flux Vector
√	√	√	√

This parameter determines the group of parameters that can be accessed during set-up/programming. There are five access levels ranging from parameters for viewing only (0: Operation Only), to parameters required for advanced applications (4: Advanced Level). The inverter defaults to a setting of “2: Quick Start” to aid in simplifying set-up. See the following table:

Setting	Description
0	Operation Only
1	User Program - Accesses parameters selected by OEM.
2	Quick Start Level (<i>factory default</i>) - For maintenance-level programming.
3	Basic Level - For basic programming in most applications.
4	Advanced Level - For advanced programming in special applications.

A1-02 Control Method Selection

Control Method

V/f Control	V/f w/ PG	Open Loop Vector	Flux Vector
√	√	√	√

Select the control method best suited for your application.

Setting	Description
0	V/f Control - For general-purpose and multiple motor applications.
1	V/f with PG Feedback - For general-purpose applications requiring closed loop speed control.
2	Open Loop Vector (<i>factory default</i>) - For applications requiring open loop speed control, higher torque at low speeds (150% torque below 1Hz).
3	Flux Vector - For applications requiring precise speed and torque control, including zero speed control. Uses encoder feedback.

A1-03 Operator Status

Init Parameters

V/f Control	V/f w/ PG	Open Loop Vector	Flux Vector
√	√	√	√

Use this parameter to re-initialize the inverter to its factory default settings. It is also possible to re-initialize the inverter to settings as determined by the user. See the G5 Programming Manual for further details on the user initialization.

Setting	Description
0	No Initialization (<i>factory default</i>)
1110	User Initialization
2220	2-Wire Initialization
3330	3-Wire Initialization

A1-04 Password Entry

Enter Password

V/f Control	V/f w/ PG	Open Loop Vector	Flux Vector
√	√	√	√

This parameter allows the password lock-out of users from prohibited parameters. This parameter is used in conjunction with Function A2, the user parameters group. When the “user program” access level is selected and the programming is locked via the A1-04 password, only those parameters in group A1 and A2 can be accessed. All other parameters cannot be viewed.

Main Menu: Programming <ENTER>

B1-01 Frequency Reference Selection

Reference Source

B1-02 Operation Method Selection

Run Source

V/f Control	V/f w/ PG	Open Loop Vector	Flux Vector
√	√	√	√
√	√	√	√

B1-01 and B1-02 determine how the inverter is to receive a frequency reference and a start/stop command, respectively. Frequency reference and run command can be set independently as shown below:

Setting	Description
0	Command from digital operator
1	Command from control circuit terminal (<i>factory default</i>)
2	Command from serial communication
3	Command from option card
4	Engineering Workstation (EWS) - For use with CP-717 <1110>

By depressing the LOCAL/REMOTE key on the digital operator, the operation mode can be selected as shown below:

- Local: Operation according to frequency reference and run command from digital operator.
- Remote: Operation according to frequency reference and run command set by *B1-01* & *B1-02*.

The digital operator is reset to remote operation when power is cycled.

B1-03 Stopping Method Selection

Stopping Method

V/f Control	V/f w/ PG	Open Loop Vector	Flux Vector
√	√	√	√

This function selects the stopping method suitable for the particular application.

Setting	Description
0	Deceleration to stop (<i>factory default</i>)
1	Coast to stop
2	DC injection to stop
3	Coast to stop with timer

· Deceleration to Stop (*B1-03 = "0"*)

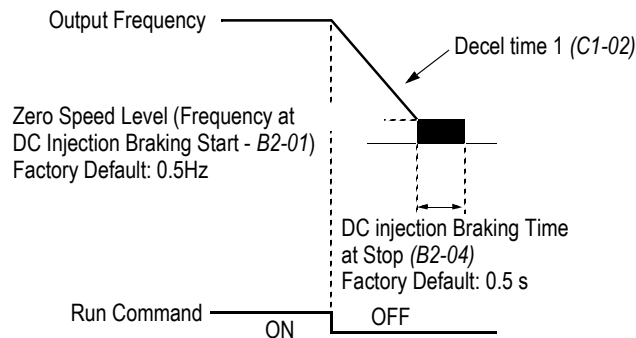

Figure 19 Stopping Method - Deceleration to Stop

Upon removal of the FWD (REV) run command, the motor decelerates at a deceleration rate determined by the time set in deceleration time 1 (*C1-02*) and DC injection braking is applied immediately before stop. If the deceleration time is short or the load inertia is large, an overvoltage fault (OV) may occur during deceleration. In this case, increase the deceleration time or install an optional braking resistor/unit.

Braking torque: without braking resistor, approx. 20% of motor rated torque
with braking resistor, approx. 150% of motor rated torque

· Coast to Stop (*B1-03 = "1"*)

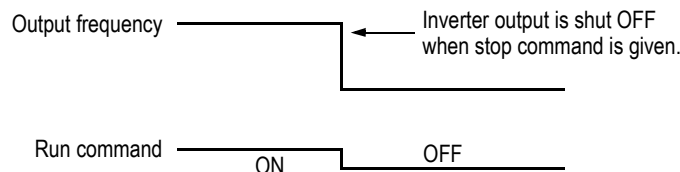

Figure 20 Stopping Method - Coast to Stop

Upon removal of the FWD (REV) run command, the motor coasts. After a stop command is given, a run command can be accepted, but operation does not start until after the minimum baseblock time (*L2-03*) elapses.

- DC Injection Braking Stop ($B1-03 = "2"$)

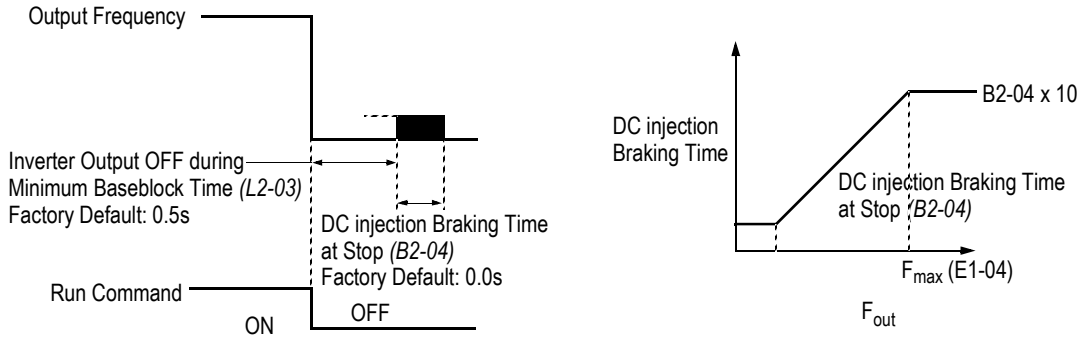

Figure 21 Stopping Method - DC Injection Braking Stop

Upon removal of the FWD (REV) run command, the motor brakes to stop, according to the DC injection braking time at stop set in $B2-04$. If this value is set to "0" (*factory default*), DC injection braking is disabled, and the motor coasts to stop. When choosing this function, note that the actual stop time from maximum frequency is the time set in $B2-04$ multiplied by 10 (see the figure above). This stopping method is disabled during flux vector control.

- Coast to Stop with Timer 1 ($B1-03 = "3"$)

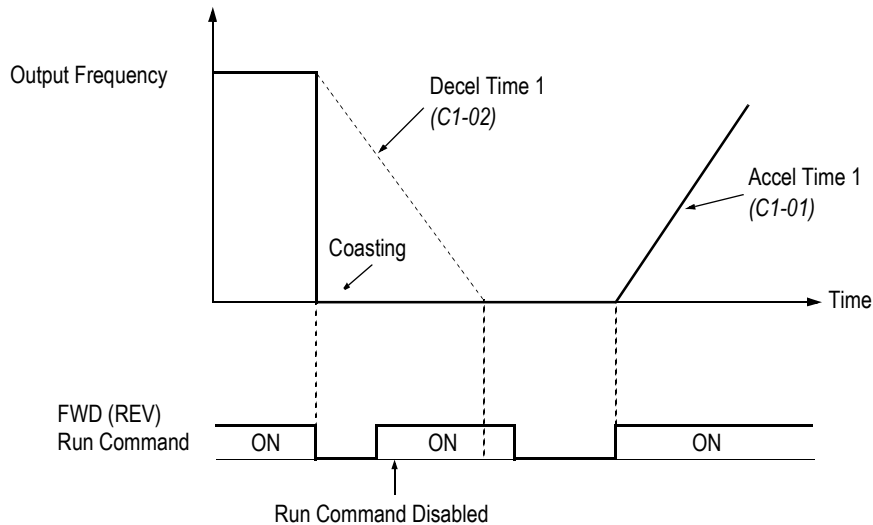

Figure 22 Stopping Method - Coast to Stop w/ Timer

After a stop command is given, a run command is not accepted while the coast to stop timer $C1-02$ elapses (same as Decel Time 1). After the timer runs out, another run command must be given for the inverter to begin acceleration. This stopping method is disabled during flux vector control.

C1-01 Acceleration time 1 *Accel Time 1*
C1-02 Deceleration time 1 *Decel Time 1*
 Setting Range: 0.00 to 6000.0s
 Factory Default: 10.0s

V/f Control	V/f w/ PG	OpenLoop Vector	Flux Vector
√	√	√	√
√	√	√	√

Acceleration time 1 sets the time necessary for the output frequency to accelerate from 0Hz to maximum output frequency as set in parameter E1-04. Deceleration time 1 sets the time necessary for the output frequency to decelerate from the maximum output frequency to 0Hz.

D1-01 Preset Frequency Reference 1 *Reference 1*
D1-02 Preset Frequency Reference 2 *Reference 2*
D1-03 Preset Frequency Reference 3 *Reference 3*
D1-04 Preset Frequency Reference 4 *Reference 4*
 Setting Range: 0.0 to 400.0Hz
 Factory Default: 0.0Hz

V/f Control	V/f w/ PG	OpenLoop Vector	Flux Vector
√	√	√	√
√	√	√	√
√	√	√	√
√	√	√	√

Up to 4 preset speed references (including jog) can be set through multi-function contact input function selections in the Quick-Start mode. Terminals 6 and 7 are factory defaulted to multi-step speed inputs 1 and 2, respectively. See the following table for programming preset speed references in the Quick-Start mode.

Terminal 5	Terminal 6	Speed Reference
Open	Open	Speed Reference 1 - Set Reference Source (<i>B1-01</i>) to "0".
Closed	Open	Speed Reference 2 (When H3-05 ≠ 0 and H3-09 ≠ 0)
Open	Closed	Speed Reference 3
Closed	Closed	Speed Reference 4

Note: 9 preset references can be set in the Advanced modes.

D1-09 Jog Frequency Reference *JOG Reference*

V/f Control	V/f w/ PG	OpenLoop Vector	Flux Vector
√	√	√	√

The jog frequency reference can be set in this parameter. In the Quick-Start mode, depress the JOG key on the digital operator, or close terminal 7 when parameter H1-05 is set to "6", to use this function. The jog command always has priority over other reference commands. When using terminal 7 to select the jog frequency, a separate run command must be applied to run the inverter.

E1-01 *Input Voltage*

Input Voltage

V/f Control	V/f w/ PG	Open Loop Vector	Flux Vector
√	√	√	√

Setting Range: 155 to 255V (230V class), 310 to 510V (460V class), 445 to 733V (575V class)
 Factory Default: 230V, 460V, 575V

Set this parameter to the inverter input supply voltage in units of 1V. This parameter does not have to be set to the exact incoming voltage level. The nominal voltage is normally sufficient (i.e. 230V, 380V, 460V, 575V).

E1-02 *Motor Selection*

Motor Selection

V/f Control	V/f w/ PG	Open Loop Vector	Flux Vector
√	√	√	√

Select between fan-cooled, blower-cooled, and vector duty motor types with this parameter. This parameter sets the motor overload (OL1) protection to match typical motor characteristics. Set this parameter to “0” for standard TEFC motors, as these motors typically have a limited constant torque speed range. Set to “1” for standard blower-cooled motors with a constant torque speed range of 10:1. Set to “2” for vector duty motors which have a 100:1 or 1000:1 speed range or when full torque at zero speed is required.

Setting	Description
0	Fan-cooled motor characteristics (<i>factory default</i>)
1	Blower-cooled motor characteristics
2	Vector duty motor <1110>

E1-03 *V/f Pattern Selection*

V/f Selection

V/f Control	V/f w/ PG	Open Loop Vector	Flux Vector
√	√	—	—

Choose a preset V/f pattern for operation in V/f modes only. It may be necessary to change the V/f pattern when using a high-speed motor, or when special torque adjustment is required in the application.

Set values 0 to E: Preset V/f pattern can be selected (E1-04 through E1-13 are fixed).
F: Custom V/f pattern can be set (*factory default*) (E1-04 through E1-13 can be set individually).

Set the V/f pattern according to the applications described in the table on the following page:

Preset V/f Patterns

		Specifications	E1-03	V/f Pattern *1			Specifications	E1-03	V/f Pattern *1
General-purpose	50Hz		0		High Starting Torque *2	50Hz	High Starting Torque 1	8	
			1				High Starting Torque 2	9	
	60Hz Saturation	1		60Hz		High Starting Torque 1	A		
	50Hz Saturation	2		High Starting Torque 2		B			
	72Hz		3			90Hz		C	
Variable Torque	50Hz	Variable Torque 1	4		High Speed Operation	120Hz		D	
		Variable Torque 2	5				180Hz	E	
	60Hz	Variable Torque 1	6						
		Variable Torque 2	7						

Notes:

- *1 The following conditions must be considered when selecting a V/f pattern:
 - The voltage and frequency characteristics of the motor.
 - The maximum speed of the motor.
- *2 Select a high starting torque V/f pattern only under the following conditions:
 - The wiring distance is long - 492ft (150m) and above.
 - Large voltage drop at start-up.
 - AC reactor is connected to the inverter's input or output.
 - A motor rated below the nominal output of the inverter is used.
- *3 Voltage in preset patterns is doubled for 460V class inverters. The 575V patterns are 2.5 times as large as the 230V patterns.

Custom V/f Pattern

Set up a custom V/f pattern by setting parameter *E1-03* to “F”, and then setting the values in parameters *E1-04* to *E1-10*.

<i>E1-04</i> Maximum Frequency	Max Frequency
<i>E1-05</i> Maximum Voltage	Max Voltage
<i>E1-06</i> Maximum Voltage Output Frequency	Base Frequency
<i>E1-07</i> Middle Output Frequency	Mid Frequency A
<i>E1-08</i> Middle Output Voltage	Mid Voltage A
<i>E1-09</i> Minimum Output Frequency	Min Frequency
<i>E1-10</i> Minimum Output Voltage	Min Voltage
<i>E1-13</i> Motor Base Voltage	Base Voltage

V/f Control	V/f w/ PG	Open Loop Vector	Flux Vector
√	√	√	√
√	√	√	√
√	√	√	√
√	√	–	–
√	√	–	–
√	√	√	–
√	√	–	–
–	–	√	√

Be sure to satisfy the following conditions for setting parameters *E1-04* to *E1-10*:
 $E1-09 \leq E1-07 < E1-06 \leq E1-04$

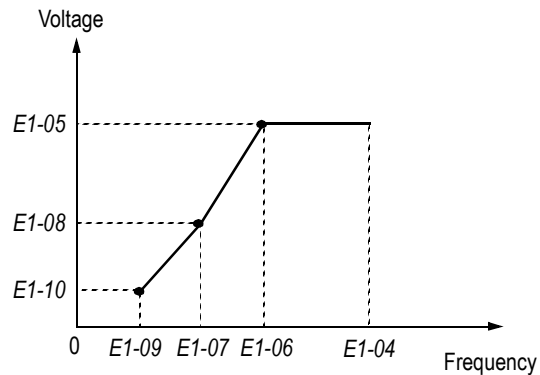

Figure 23 Custom V/f Pattern Setting

Parameter No.	Name	Unit	Setting Range	Factory Default
<i>E1-04</i>	Maximum output frequency	0.1 Hz	50.0 to 400 Hz	60.0 Hz
<i>E1-05</i>	Maximum voltage	0.1 V	0.1 to 255 V *	230 V *
<i>E1-06</i>	Maximum voltage output frequency (base frequency)	0.1 Hz	0.2 to 400 Hz	60.0 Hz
<i>E1-07</i>	Mid. output frequency	0.1 Hz	0.1 to 399 Hz	3.0 Hz
<i>E1-08</i>	Mid. output frequency voltage	0.1 V	0.1 to 255 V *	17.2 V *
<i>E1-09</i>	Minimum output frequency	0.1 Hz	0.1 to 10.0 Hz	1.5 Hz
<i>E1-10</i>	Minimum output frequency voltage	0.1 V	0.1 to 50.0 V *	10.3 V *

* For 460V class units, the value is twice that of 230V class units. For 575V class units the value is 2.5 times the 230V value.

Increasing the voltage in the V/f pattern increases motor torque. However, when setting a custom V/f pattern, increase the voltage gradually while monitoring the motor current, to prevent:

- Inverter fault trips as a result of motor overexcitation
- Motor overheat or excessive vibration

V/F Patterns for Inverter Capacity 0.4 ~ 1.5kW for 230V Class*

Parameter No.	Name	Unit	Factory Setting							
			0	1	2	3	4	5	6	7
E1-03	V/f Pattern Selection	—	0	1	2	3	4	5	6	7
E1-04	Max. Output Frequency	Hz	50.0	60.0	60.0	72.0	50.0	50.0	60.0	60.0
E1-05	Max. Voltage	V	230.0	230.0	230.0	230.0	230.0	230.0	230.0	230.0
E1-06	Max. Voltage Frequency	Hz	50.0	60.0	50.0	60.0	50.0	50.0	60.0	60.0
E1-07	Mid. Output Frequency	V	2.5	3.0	3.0	3.0	25.0	25.0	30.0	30.0
E1-08	Mid. Output Frequency Voltage	V	17.2	17.2	17.2	17.2	40.2	57.5	40.2	57.5
E1-09	Min. Output Frequency	Hz	1.3	1.5	1.5	1.5	1.3	1.3	1.5	1.5
E1-10	Min. Output Frequency Voltage	V	10.3	10.3	10.3	10.3	9.2	10.3	9.2	10.3

* For 460V class units, the value is twice that of 230V class units. For 575V class units the value is 2.5 times the 230V value.

V/F Patterns for Inverter Capacity 0.4 ~ 1.5kW for 230V Class* (Continued)

Parameter No.	Name	Unit	Factory Setting							
			8	9	A	B	C	D	E	F
E1-03	V/f Pattern Selection	—	8	9	A	B	C	D	E	F
E1-04	Max. Output Frequency	Hz	50.0	50.0	60.0	60.0	90.0	120.0	180.0	60.0
E1-05	Max. Voltage	V	230.0	230.0	230.0	230.0	230.0	230.0	230.0	230.0
E1-06	Max. Voltage Frequency	Hz	50.0	50.0	60.0	60.0	60.0	60.0	60.0	60.0
E1-07	Mid. Output Frequency	V	2.5	2.5	3.0	3.0	3.0	3.0	3.0	3.0
E1-08	Mid. Output Frequency Voltage	V	21.8	27.6	21.8	27.6	17.2	17.2	17.2	17.2
E1-09	Min. Output Frequency	Hz	1.3	1.3	1.5	1.5	1.5	1.5	1.5	1.5
E1-10	Min. Output Frequency Voltage	V	12.6	14.9	12.6	17.2	10.3	10.3	10.3	10.3

* For 460V class units, the value is twice that of 230V class units. For 575V class units the value is 2.5 times the 230V value.

V/F Patterns for Inverter Capacity 2.2 ~ 45kW for 230V Class*

Parameter No.	Name	Unit	Factory Setting							
			0	1	2	3	4	5	6	7
E1-03	V/f Pattern Selection	—	0	1	2	3	4	5	6	7
E1-04	Max. Output Frequency	Hz	50.0	60.0	60.0	72.0	50.0	50.0	60.0	60.0
E1-05	Max. Voltage	V	230.0	230.0	230.0	230.0	230.0	230.0	230.0	230.0
E1-06	Max. Voltage Frequency	Hz	50.0	60.0	50.0	60.0	50.0	50.0	60.0	60.0
E1-07	Mid. Output Frequency	V	2.5	3.0	3.0	3.0	25.0	25.0	30.0	30.0
E1-08	Mid. Output Frequency Voltage	V	16.1	16.1	16.1	16.1	40.2	57.5	40.2	57.5
E1-09	Min. Output Frequency	Hz	1.3	1.5	1.5	1.5	1.3	1.3	1.5	1.5
E1-10	Min. Output Frequency Voltage	V	8.0	8.0	8.0	8.0	6.9	8.0	6.9	8.0

* For 460V class units, the value is twice that of 230V class units. For 575V class units the value is 2.5 times the 230V value.

V/F Patterns for Inverter Capacity 2.2 ~ 45kW for 230V Class* (Continued)

Parameter No.	Name	Unit	Factory Setting							
			8	9	A	B	C	D	E	F
E1-03	V/f Pattern Selection	—	8	9	A	B	C	D	E	F
E1-04	Max. Output Frequency	Hz	50.0	50.0	60.0	60.0	90.0	120.0	180.0	60.0
E1-05	Max. Voltage	V	230.0	230.0	230.0	230.0	230.0	230.0	230.0	230.0
E1-06	Max. Voltage Frequency	Hz	50.0	50.0	60.0	60.0	60.0	60.0	60.0	60.0
E1-07	Mid. Output Frequency	V	2.5	2.5	3.0	3.0	3.0	3.0	3.0	3.0
E1-08	Mid. Output Frequency Voltage	V	20.7	26.4	20.7	26.4	16.1	16.1	16.1	16.1
E1-09	Min. Output Frequency	Hz	1.3	1.3	1.5	1.5	1.5	1.5	1.5	1.5
E1-10	Min. Output Frequency Voltage	V	10.3	12.6	10.3	14.9	8.0	8.0	8.0	8.0

* For 460V class units, the value is twice that of 230V class units. For 575V class units the value is 2.5 times the 230V value.

V/F Patterns for Inverter Capacity 55 ~ 300kW for 230V Class*

Parameter	Name	Unit	Factory Setting							
			0	1	2	3	4	5	6	7
E1-03	V/f Pattern Selection	–	0	1	2	3	4	5	6	7
E1-04	Max. Output Frequency	Hz	50.0<21>	60.0	60.0	72.0<21>	50.0<21>	50.0<21>	60.0	60.0
E1-05	Max. Voltage	V	230.0	230.0	230.0	230.0	230.0	230.0	230.0	230.0
E1-06	Max. Voltage Frequency	Hz	50.0<21>	60.0	50.0<21>	60.0	50.0<21>	50.0<21>	60.0	60.0
E1-07	Mid. Output Frequency	V	2.5 <21>	3.0	3.0	3.0	25.0<21>	25.0 <21>	30.0	30.0
E1-08	Mid. Output Frequency Voltage	V	13.8<21>	13.8<21>	13.8<21>	13.8<21>	40.2<21>	57.5<21>	40.2<21>	57.5<21>
E1-09	Min. Output Frequency	Hz	1.3 <21>	1.5	1.5	1.5	1.3<21>	1.3 <21>	1.5	1.5
E1-10	Min. Output Frequency Voltage	V	6.9	6.9	6.9	6.9	5.7<21>	6.9	5.7 <21>	6.9

* For 460V class units, the value is twice that of 230V class units. For 575V class units the value is 2.5 times the 230V value.

V/F Patterns for Inverter Capacity 55 ~ 300kW for 230V Class* (Continued)

Parameter	Name	Unit	Factory Setting							
			8	9	A	B	C	D	E	F
E1-03	V/f Pattern Selection	–	8	9	A	B	C	D	E	F
E1-04	Max. Output Frequency	Hz	50.0<21>	50.0<21>	60.0	60.0	90.0<21>	120.0<21>	180.0<21>	60.0
E1-05	Max. Voltage	V	230.0	230.0	230.0	230.0	230.0	230.0	230.0	230.0
E1-06	Max. Voltage Frequency	Hz	50.0<21>	50.0<21>	60.0	60.0	60.0	60.0	60.0	60.0
E1-07	Mid. Output Frequency	V	2.5<21>	2.5<21>	3.0	3.0	3.0	3.0	3.0	3.0
E1-08	Mid. Output Frequency Voltage	V	17.2<21>	23.0<21>	17.2<21>	23.0<21>	13.8<21>	13.8<21>	13.8<21>	13.8<21>
E1-09	Min. Output Frequency	Hz	1.3<21>	1.3<21>	1.5	1.5	1.5	1.5	1.5	1.5
E1-10	Min. Output Frequency Voltage	V	8.0<21>	10.3<21>	8.0<21>	12.6<21>	6.9	6.9	6.9	6.9

* For 460V class units, the value is twice that of 230V class units. For 575V class units the value is 2.5 times the 230V value.

E2-01 Motor Rated Current

Motor Rated FLA

V/f Control	V/f w/ PG	Open Loop Vector	Flux Vector
√	√	√	√

Sets the motor rated current in units of 0.01A for inverter sizes 7.5kW and smaller; 0.1A for sizes 11kW and larger. This setting varies depending on the inverter model setting (O2-04).

E2-02 Motor Rated Slip Frequency

Motor Rated Slip

V/f Control	V/f w/ PG	Open Loop Vector	Flux Vector
—	—	√	√

Setting range: 0.00 to 20.00Hz

Sets the motor rated slip frequency in units of 0.01Hz. This setting varies depending on the motor. Use the following equation to calculate the motor rated slip frequency:

$$f_s = f - \frac{(N \cdot P)}{120}$$

where:

f_s : slip frequency (Hz)

f: motor rated frequency (Hz)

N: motor rated speed (rpm)

P: number of motor poles

E2-03 Motor No-Load Current

No-Load Current

V/f Control	V/f w/ PG	Open Loop Vector	Flux Vector
—	—	√	√

Sets the motor no-load current in units of 0.01A for inverter sizes 7.5kW and smaller; 0.1A for sizes 11kW and larger. This setting varies depending on the inverter model setting (O2-04).

E2-04 Number of Motor Poles

Number of Poles

V/f Control	V/f w/ PG	Open Loop Vector	Flux Vector
—	√	—	√

Setting Range: 2 to 48 poles
Factory Default: 4 poles

Sets the number of motor poles.

F1-04 PG Constant

PG Pulses/Rev

V/f Control	V/f w/ PG	Open Loop Vector	Flux Vector
—	√	—	√

Setting Range: 0 to 60000
Factory Default: 1024

Sets the encoder pulse count (per revolution) for the closed loop control modes (VF w/PG and Flux Vector).

Main Menu: Auto-Tuning <ENTER>

Adaptation to most motors manufactured worldwide is possible with the VS-616G5 automatic tuning function. Available in both open loop vector and flux vector control modes, the inverter prompts the user for minimal motor information, then guides the user through a quick, simple tuning process.

Below is the motor data required for automatic tuning in the quick-start mode:

Name	Description	V/f Control	V/f w/ PG	Open Loop Vector	Flux Vector
Motor Rated Voltage	Sets motor's rated voltage in VAC.	–	–	√	√
Motor Rated Current	Sets motor's rated current in A.	–	–	√	√
Motor Rated Frequency	Sets motor's rated frequency in Hz.	–	–	√	√
Motor Rated Speed	Sets motor's rated speed in rpm.	–	–	√	√
Number of Motor Poles	Sets the number of motor poles.	–	–	√	√
Motor Selection	Chooses connected motor as 1st or 2nd motor.	–	–	√	√

Be sure to uncouple the motor before beginning auto-tuning. After scrolling through tuning parameters using ^ key, depress Run key to begin auto-tuning. During tuning, “Tune Proceeding” flashes on the digital operator display. After complete, “Tune Successful” is displayed.

Note: If the Stop key is depressed during tuning, auto-tuning is interrupted and the motor coasts to stop. The data changed during tuning returns to its original values.

After tuning is complete, depress the Menu key to exit the auto-tuning mode.

This page intentionally left blank.

- CHAPTER 4 -

DIAGNOSTICS

<u>Section</u>	<u>Description</u>	<u>Page</u>
4	DIAGNOSTICS	
	Precautions	62
4.1	MAINTENANCE & INSPECTION	63
	Periodic Inspection	63
	Parts Replacement Schedule	63
4.2	ALARM & FAULT DISPLAYS	64
	Inverter Alarms & Faults	64
	Motor Faults	68

WARNING

PRECAUTIONS

- 1) Never touch high voltage terminals in the inverter.
- 2) Replace all protective covers before powering up the inverter. When removing the cover, be sure to shut OFF the power supply to the inverter.
- 3) Perform maintenance or inspection only after verifying that the charge LED has gone OFF, after the main circuit power supply is turned OFF.
- 4) Only authorized personnel should be permitted to perform maintenance, inspections or parts replacement.

Failure to observe these precautions highlighted in this manual will expose the user to high voltages, resulting in equipment damage, serious injury or death.

CAUTION

PRECAUTIONS

- 1) The control PCB board employs CMOS ICs. Do not touch the CMOS elements.
- 2) Do not connect or disconnect wiring or connectors while power is applied to the circuit.

Failure to observe these precautions may result in equipment damage.

4.1 MAINTENANCE & INSPECTION

This section describes basic maintenance and inspection procedures for the VS-616G5.

Periodic Inspection

The VS-616G5 will function longer if it is kept clean, cool and dry, and if all precautions highlighted in this manual are observed. Periodically inspect the inverter as described in the table below to prevent accidents and to ensure high performance with high reliability.

To prevent electrical shock, disconnect all power before servicing the inverter. Then wait at least five minutes after the power supply is disconnected and all LEDs are extinguished.

Component	Check	Corrective Action
External Terminals, Connectors, Mounting Screws, etc.	Loose screws or connectors	Securely tighten.
Heatsink	Build-up of dust and dirt	Blow with dry, compressed air [39.2×10^4 to 58.8×10^4 Pa (4 to 6kg·cm ²) pressure].
Printed Circuit Board (PCB)	Accumulation of conductive dust or oil	Blow with dry, compressed air [39.2×10^4 to 58.8×10^4 Pa (4 to 6kg·cm ²) pressure]. If dust and oil cannot be removed, replace the board.
Cooling Fan	For abnormal noise and vibration	Replace the cooling fan.
Power Components	Accumulation of dust and dirt	Blow with dry, compressed air [39.2×10^4 to 58.8×10^4 Pa (4 to 6kg·cm ²) pressure].
Smoothing Capacitor	Discoloration or odor	Replace the capacitor or the inverter.

Parts Replacement Schedule

Replace the following parts periodically, for long, safe, trouble-free operation of the VS-616G5:

Parts	Approximate Interval	Remarks
Cooling Fan	2 to 3 years	Replace with new one.
Smoothing Capacitor	5 years	Replace with new one (after inspection).
Breakers or Relays	--	Decide after inspection.
Fuses	10 years	Replace with new one.
Aluminum Electrolytic Capacitor on PCB Board	5 years	Replace with new one (after inspection).

Optimum operating conditions:

Ambient temperature: 86°F yearly average
 Load factor: 80% or below
 Operation rate: 12 hours or less per day

4.2 ALARM & FAULT DISPLAYS

This section describes the alarm and fault displays, explanations for fault conditions, and corrective actions to be taken if the VS-616G5 malfunctions.

Inverter Alarms & Faults

When the VS-616G5 detects a fault, the fault is displayed on the digital operator and activates a fault contact output, after which the motor coasts to a stop. Check the causes listed in the table below and take the corresponding corrective actions. To restart the inverter, remove any run command and turn ON the reset input signal or depress the RESET key on the digital operator, or cycle power to reset the stop status. If taking the corrective actions described does not solve the problem, contact your Yaskawa representative immediately.

Unlike faults, alarms do not activate fault contact outputs. After the cause of the alarm is corrected, the inverter returns to its former operation status automatically.

Fault Diagnosis and Corrective Actions

Fault Display	Name	Description	Corrective Action	Class
UV1 DC Bus Undervolt	Main circuit undervoltage (PUV)	Undervoltage in the DC main circuit during running. <u>Detection level</u> 230 V class: Approx. 190 V or less 460 V class: Approx. 380 V or less 575 V class: Approx. 546 V or less	<ul style="list-style-type: none"> · Check the power supply wiring. · Correct the line voltage 	A
UV2 CTL PS Undervolt	Control circuit undervoltage (CUV)	Undervoltage in the control circuit during running.		A
UV3 MC Answerback	MC fault	The pre-charge contactor opened during running.		A
UV Under Voltage	Momentary power loss	<ul style="list-style-type: none"> · The main circuit DC voltage fell below the PUV level. · The control power source fell below the CUV level. · The pre-charge contactor opened. 	--	B
OC Overcurrent	Overcurrent (OC)	The inverter output current exceeded the OC level.	<ul style="list-style-type: none"> · Check the motor coil resistance. · Extend the accel/decel time. · Check the motor insulation. · Multi-meter check. 	A
GF Ground Fault	Ground fault (GF)	Inverter output grounding current exceeded 50% of inverter rated current.	<ul style="list-style-type: none"> · Check that motor insulation has not deteriorated. · Check that connection between inverter and motor is not damaged. 	A

Fault Display	Name	Description	Corrective Action	Class
OV Overvoltage	Overvoltage (OV)	The main circuit direct current voltage exceeded the OV level. <u>Detection level</u> 230 V class: Approx. 410 V 460 V class: Approx. 820 V 575 V class: Approx. 1040 V	Extend the deceleration time, add braking circuit.	A
SC Short Circuit	Load short-circuit (SC)	Inverter output (load) is short-circuited.	· Check the motor coil resistance. · Check the motor installation.	A
PUF DC Bus Fuse Open	Fuse blown (FU)	· The DC bus fuse is blown. · The output transistors were damaged.	Check for damaged transistor, load side short circuit, grounding, etc.	A
OH Heatsink Over tmp	Heatsink overheat (OH1)	The transistor heatsink temperature exceeded the allowable value.	Check the fan and ambient temperature.	A
OL1 Motor Overloaded	Motor overload (OL1)	Inverter output exceeded the motor overload level.	Reduce the load.	A
OL2 Inv Overloaded	Inverter overload (OL2)	Inverter output exceeded the inverter overload level.	Reduce the load, extend the acceleration time.	A
PF Input Pha Loss	Input open-phase	Inverter input power supply has open phase. Large unbalance in input voltage.	· Check the line voltage. · Re-tighten the input terminal screws.	A
LF Output Pha Loss	Output open-phase	Inverter output has open-phase.	· Check the output wiring. · Check the motor impedance. · Re-tighten the output terminal screws.	A
RR Dyn Brk Transistr	Braking transistor failure	The braking transistor has failed.	The inverter requires repair.	A
RH Dyn Brk Resistor	Braking resistor unit overheat	The braking resistor unit temperature has exceeded the allowable value. (Protects only inverter built-in type)	Reduce the regenerative load.	A
OS Over speed	Overspeed (OS)	The motor speed exceeded the over-speed level.	--	A
PGO PG open	PG open circuit (PGO)	The PG line is broken.	· Check the PG line. · Check the condition of the motor lock or the load.	A
DEV Speed Deviation	Speed deviation (DEV)	The deviation of the speed reference and speed feedback exceeded the regulation level.	Check the load.	B
EF External Fault	Simultaneous forward/reverse run commands	Both FWD and REV run commands are simultaneously input for 500ms or longer.	Check sequence circuit.	B
BB Base Block	External baseblock	External baseblock command is input from control circuit terminal.	Check sequence circuit.	B

Fault Display	Name	Description	Corrective Action	Class
EF3 External Fault 3	External fault at terminal 3	Fault occurred in the external control circuit.	Check the condition of the input terminal. If the LED lights when terminal is not connected, then the inverter requires repair.	A
EF4 External Fault 4	External fault at terminal 4	Fault occurred in the external control circuit.	Check the condition of the input terminal. If the LED lights when terminal is not connected, then the inverter requires repair.	B
EF5 External Fault 5	External fault at terminal 5			
EF6 External Fault 6	External fault at terminal 6			
EF7 External Fault 7	External fault at terminal 7			
EF8 External Fault 8	External fault at terminal 8			
OPE01 kVA Selection	kVA setting error (OPE01)	Inverter kVA setting error.	Check and set the parameter data (O2-04).	C
OPE02 Limit	Parameter setting range error (OPE02)	Parameter data is out of range.	Check the parameter data settings.	C
OPE03 Terminal	Multi-function input setting error (OPE03)	· Multi-function input settings in H1-01 to H1-06 are not in ascending order. · Or, set values other than "F" are overlapping.	Check the function selection.	C
OPE10 V/f	V/f data setting error (E1-04 to E1-10)	V/f data is set such that the following equation is <i>not</i> satisfied: $E1-04 \geq E1-06 > E1-07 \geq E1-09$	Check the parameter data settings.	C
OPE11 FC/ On-Dly	Parameter setting error	When one of the following setting errors occurs: · Carrier frequency upper limit (C6-01) > 5kHz, and Carrier frequency lower limit (C6-02) ≤ 5kHz · Carrier frequency proportional gain (C6-03) > 6 and (C6-01) < (C6-02)	Check the parameter data settings.	C
ERR EEPROM R/W Err	EEPROM writing fault (ERR)	EEPROM internal data did not match when initializing the parameter.	Replace the control board.	B
CALL Serial Com Call	SI-B transmission error	Control data was not received correctly when power supply was turned ON.	Check transmission devices and transmission signals.	C
CE Memobus Com Err	Transmission error	Control data was not received correctly when power supply was turned ON.	Check transmission devices and transmission signals.	A

Fault Display	Name	Description	Corrective Action	Class
CPF00 COM-ERR(OP&INV)	Control circuit fault 1 (CPF00) Digital perator transmission fault	· Transmission between the inverter and digital operator cannot be established 5 seconds after supplying power. · MPU peripheral element check fault (on-line)	· Insert the operator connector again. · Check the wiring of control circuit. · Replace the control board.	A
CPF01 COM-ERR(OP&INV)	Control circuit fault 2 (CPF01) Digital perator transmission fault	· Transmission between the inverter and digital operator is established once after supplying power, but later transmission fault continues for more than 2 seconds. · MPU peripheral element check fault (on-line).	· Insert the digital operator connector again. · Check the digital control circuit wiring. · Replace the control board.	A
CPF02 BB Circuit Err	Baseblock circuit fault (CPF02)	Inverter PCB control board fault.	Replace the control board.	A
CPF03 EEPROM Error	EEPROM fault (CPF03)			A
CPF04 Internal A/D Err	CPU internal A/D converter fault (CPF04)			A
CPF05 External A/D Err	CPU external A/D converter fault (CPF05)			A
CPF06 Option Error	Option connection fault (CPF06)	The option card is not installed correctly.	Install the option card again.	A
CPF20 Option A/D Error	A/D converter fault in analog speed reference card (CPF20)	Option card (AI-14B) A/D converter fault	Replace the option card.	A

Classes are described as follows:

- A: Major fault. Motor coasts to stop, operation indicator illuminates, and fault contact output (terminals 18 & 19) is activated.
- B: Fault. Operation continues, operation indicator illuminates, and multi-function fault signal is output (when multi-function output is selected). Fault contact output is *not* activated.
- C: Alarm (warning). Operation cannot be performed, and operation indicator illuminates, but *no* fault signal is output.

Motor Faults

If a motor fault occurs, follow the checkpoints listed in the table below and take the corresponding corrective actions. If taking the corrective actions described does not solve the problem, contact your Yaskawa representative immediately.

Motor Faults and Corrective Actions

Fault	Check Point	Corrective Action
Motor does not rotate	Power supply voltage applied to power supply terminals L1, L2, L3? Charge LED is ON?	<ul style="list-style-type: none"> · Turn ON power supply. · Turn OFF power supply, and then ON again. · Check power supply voltage. · Make sure terminal screws are tight.
	Use rectifier type voltmeter to test. Voltage output to output terminals T1, T2, T3 correct?	Turn OFF power supply, then turn ON again.
	Motor locks due to excessive load?	Reduce the load and release the lock.
	Fault displayed in operator display?	Check troubleshooting table on page 64.
	FWD or REV run command entered?	Check the wiring.
	Frequency setting voltage entered (when using terminals 13 or 14)?	<ul style="list-style-type: none"> · Check the wiring. · Check frequency setting voltage.
	Are reference and run source settings correct?	Check reference and run source selections (B1-01, B1-02).
Motor rotation reverses	Wiring of terminals T1, T2, T3 correct?	Match wiring to the phase order of the motor leads T1, T2, T3.
	FWD and REV wiring run signals entered?	Correct the wiring.
Motor rotates, but variable speed not available.	Wiring of frequency setting circuit correct?	Correct the wiring.
	Are reference and run source settings correct?	Check reference and run source selections (B1-01, B1-02).
	Load excessively large?	Reduce the load.
Motor rpm too high or too low	Motor ratings (number of poles, voltage) correct?	Check motor nameplate specifications.
	Accel/decel speed change ratio for gears, etc. correct?	Check speed changer (gears, etc.)
	Maximum frequency set value correct?	Check the maximum frequency set value.
	Use rectifier voltmeter. Voltage between motor terminals not excessively reduced?	Check V/f characteristics values.
Motor rpm not stable during operation	Load excessively large?	Reduce the load.
	Load variation excessively large?	<ul style="list-style-type: none"> · Reduce the load variation. · Increase inverter motor capacity.
	3-phase or single-phase power supply used? For 3-phase power supply, open phase?	<ul style="list-style-type: none"> · For 3-phase power supply, check the wiring if power supply is open phase. · For single-phase power supply, connect AC reactor to the power supply.

APPENDIX

<u>Section</u>	<u>Description</u>	<u>Page</u>
A	APPENDIX	
A.1	VS-616G5 PARAMETER TREE	70
A.2	VS-616G5 MONITOR DISPLAY	71
A.3	VS-616G5 PARAMETERS	76
A.4	BRAKING CONNECTION DIAGRAMS	107
A.5	CE CONFORMANCE INFORMATION	108

A.1 VS-616G5 Parameter Tree

Group	Function	Parameter No.				
		Quick-start	Basic	Advanced		
MENU	Operation	U1-01	Frequency Reference	01		
		U1-02	Output Frequency	02		
		U1-03	Output Current	03		
		U1-06*	Output Voltage*	06*		
		U2	Fault trace	01-14		
		U3	Fault history	01-08		
		U1	Monitor	01-14	15-19	20-35
A	Initialize	A1	Initialize	00-04		
		A2	User parameters			01-32
Programming	B Application	B1	Sequence	01-03	04	05-08
		B2	DC braking		01-04	
		B3	Speed search			01-03
		B4	Delay timers			01, 02
		B5	PID control			01-11
		B6	Reference hold			01-04
		B7	Droop control			01, 02
		B8	Energy savings			01, 02
		B9	Zero servo			01, 02
		Auto-tuning	C Tuning	C1	Accel/decel	01, 02
C2	S-curve accel/decel					01-04
C3	Motor slip compensation				01	02-07
C4	Torque compensation				01	02-05
C5	ASR tuning				01-04	05-08
C6	Carrier frequency				01	02, 03
C7	Hunting prevention					01, 02
C8	Factory Tuning					08, 09, 30, 31
Modified constants	D Reference	D1	Preset reference	01-04, 09	05-08	
		D2	Reference limit		01, 02	
		D3	Jump frequencies		01-04	
		D4	Sequence			01, 02
		D5	Torque control			01-06
	E Motor	E1	V/f pattern 1	01-10		11-13
		E2	Motor set-up 1	01-04		05-10
		E3	Control method 2			01
		E4	V/f pattern 2			01-07
		E5	Motor set-up 2			01-03, 05, 06
	F Option	F1	PG option set-up	01	02-07	08-13
		F2	AI-14 set-up		01	
		F3	DI-08, 16 set-up		01	
		F4	AO-08, 12 set-up		01-04	05, 06
		F5	DO-02 set-up		01,02	
		F6	DO-08 set-up		01	
		F7	PO-36F set-up		01	
		F8	SI-F/G set-up			01
		F9	CP-916 set-up			01-06
	H Terminal	H1	Digital inputs		01-06	
		H2	Digital outputs		01-03	
		H3	Analog inputs		01-07	08-12
		H4	Analog outputs		01-07	
		H5	Serial communication set-up			01-05
	L Protection	L1	Motor overload		01, 02	
		L2	Power loss ridethrough		01-03	04-06
		L3	Stall prevention		01, 02, 04-06	03
		L4	Reference detection		01, 02	03-05
		L5	Fault restart		01, 02	
		L6	Torque detection		01-03	04-06
		L7	Torque limit	01-04		
		L8	Hardware protection		01	02, 03, 05, 07, 10
	O Operator	O1	Monitor select		01-04	05
		O2	Key select		01-04	05-09

* User Selectable

A.2 VS-616G5 Monitor Display (Un-XX)

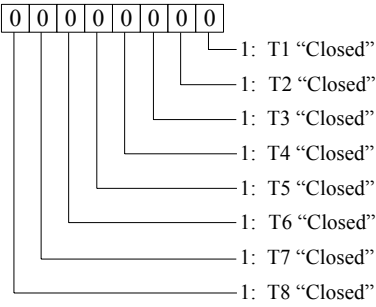
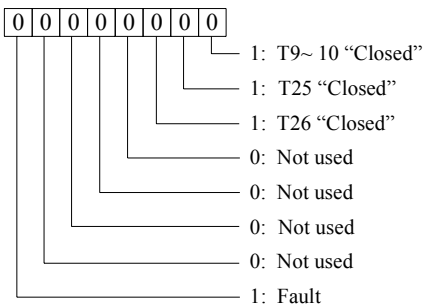
Function	Parameter No.	Name (Digital Operator Display)	Min. Unit	Description	Analog Monitor Output Level	Parameter Access Level			
						V/f	V/f w/ PG	Vector w/o PG	Vector w/ PG
Monitor	U1-01	Frequency Reference (Frequency Ref)	0.01Hz	The unit differs depending on O1-03 setting.	10V/Max. output frequency	Q	Q	Q	Q
	U1-02	Output Frequency (Output Freq)	0.01Hz	The unit differs depending on O1-03 setting.	10V/Max. output frequency	Q	Q	Q	Q
	U1-03	Output Current (Output Current)	0.1A	Minimum unit is 0.01 A for 7.5 kW or less.	10V/Inverter rated current	Q	Q	Q	Q
	U1-04	Control Method* (Control Method)	—	0: V/f control 1: V/f control with PG 2: Vector control without PG 3: Vector control with PG	—	Q	Q	Q	Q
	U1-05	Motor Speed (Motor Speed)	0.01Hz	The unit differs depending on O1-03 setting.	10V/Max. output frequency	x	Q	Q	Q
	U1-06	Output Voltage (Output Voltage)	0.1V	—	10V/200V or 400V 7575	Q	Q	Q	Q
	U1-07	DC Bus Voltage V (DC Bus Voltage)	1V	—	10V/400V or 800V	Q	Q	Q	Q
Monitor	U1-08	Output Power (Output kWatts)	0.1kW	—	10V/Inverter capacity (kW)	Q	Q	Q	Q
	U1-09	Torque Reference (Torque Reference)	0.1%	—	10V/Motor rated torque	x	x	Q	Q
	U1-10	Input Terminal Status* (Input Term Sts)	—		—	Q	Q	Q	Q
	U1-11	Output Terminal Status* (Output Term Sts)	—		—	Q	Q	Q	Q

* Cannot be changed by U1-04

Function	Parameter No.	Name (Digital Operator Display)	Min. Unit	Description	Analog Monitor Output Level	Parameter Access Level			
						V/f	V/f w/ PG	Vector w/o PG	Vector w/ PG
Monitor	U1-12	Operation Status* (Int Ctl Sts 1)	—		—	Q	Q	Q	Q
	U1-13	Elapsed Time* (Elapsed Time)	1 hour	—	—	Q	Q	Q	Q
	U1-14	Software No. at FLASH Side* (FLASH ID)	—	—	—	Q	Q	Q	Q
	U1-15	Control Circuit Terminal 13 (Term 13 Level)	0.1%	—	10V/10V	B	B	B	B
	U1-16	Control Circuit Terminal 14 Input Voltage (Term 14 Level)	0.1%	—	10V/10V or 20 mA	B	B	B	B
	U1-17	Control Circuit Terminal 16 Input (Terminal 16 Level)	0.1%	—	10V/10V	B	B	B	B
	U1-18	Motor Secondary Current (Iq) (Mot SEC Current)	0.1%	—	10V/Motor rated primary current	B	B	B	B
	U1-19	Motor Excitation Current (Mot EXC Current)	0.1%	—	10V/Motor rated primary current	x	x	B	B
	U1-20	Output Frequency after Soft-start (SFS Output)	0.01Hz	—	10V/Max. output frequency	A	A	A	A
	U1-21	ASR Input (ASR Input)	0.01%	—	10V/Max. output frequency	x	A	x	A
	U1-22	ASR Output (ASR Output)	0.01%	Analog monitor output level becomes 10V/Max. output frequency for V/f control mode with PG.	10V/Motor rated primary current	x	A	x	A
		U1-23	Speed Deviation (Speed Deviation)	0.01%	—	10V/Max. output Frequency	x	A	x
	U1-24	PID Feedback Capacity (PID Feedback)	0.01%	—	10V/Max. output Frequency	A	A	A	A

* Cannot be changed by U1-04

Function	Parameter No.	Name (Digital Operator Display)	Min. Unit	Description	Analog Monitor Output Level	Parameter Access Level			
						V/f	V/f w/ PG	Vector w/o PG	Vector w/ PG
Monitor	U1-25	D1-16H Input Status* (DI-16 Reference)	—	Displays input value according to F3-01 setting. For example: When lower 8 bit is ON, Binary selection: 256, BCD selection: 99	—	A	A	A	A
	U1-26	Output Voltage Reference Vq (Voltage Ref (Vq))	0.1V	—	10V/200V or 400V	x	x	A	A
	U1-27	Output Voltage Reference Vd (Voltage Ref (Vd))	0.1V	—	10V/200V or 400V	x	x	A	A
	U1-28	Software No. at CPU Side* (CPU ID)	—	—	—	A	A	A	A
	U1-32	ACR (q) Output (ACR (q) Output)	0.1%	—	—	x	x	A	A
	U1-33	ACR (d) Output (ACR (d) Output)	0.1%	—	—	x	x	A	A
	U1-34	OPE Detection Parameter* (OPE Detected)	—	—	—	A	A	A	A
	U1-35	No. of O Servo Moving Pulses (Zero Servo Pulse)	1	—	—	x	x	x	A
	U1-36 <1110>	PID Deviation (PID Input)	0.01%	PID reference + PID reference bias – PID feedback capacity	10V/Max. Output Frequency	A	A	A	A
	U1-37 <1110>	PID Output Capacity (PID Output)	0.01%	PID output capacity	10V/Max. Output Frequency	A	A	A	A
	U1-38 <1110>	PID Reference (PID Setpoint)	0.01%	PID reference + PID reference bias	10V/Max. Output Frequency	A	A	A	A

* Cannot be changed by U1-04

Function	Parameter No.	Name (Digital Operator Display)	Min. Unit	Description	Analog Monitor Output Level	Parameter Access Level				
						V/f	V/f w/ PG	Vector w/o PG	Vector w/ PG	
Function U2 Fault Trace	U2-01	Current Fault (Current Fault)	—	—	—	Q	Q	Q	Q	
	U2-02	Last Fault (Last Fault)	—	—	—	Q	Q	Q	Q	
	U2-03	Frequency Reference at Fault (Frequency Ref)	0.01Hz	—	—	Q	Q	Q	Q	
	U2-04	Output Frequency at Fault (Output Freq)	0.01Hz	—	—	Q	Q	Q	Q	
	U2-05	Output Current at Fault (Output Current)	0.1A	—	—	Q	Q	Q	Q	
	U2-06	Motor Speed at Fault (Motor Speed)	0.01Hz	—	—	x	Q	Q	Q	
	U2-07	Output Voltage Reference at Fault (Output Voltages)	0.1V	—	—	Q	Q	Q	Q	
	U2-08	DC Bus Voltage at Fault (DC Bus Voltage)	1V	—	—	Q	Q	Q	Q	
	U2-09	Output Power at Fault (Output kWatts)	0.1kW	—	—	Q	Q	Q	Q	
	U2-10	Torque Reference at Fault (Torque Reference)	0.1%	—	—	x	x	Q	Q	
	U2-11	Input Terminal Status at Fault (Input Term Sts)	—	—	Displays the same status as the U1-10.	—	Q	Q	Q	Q
	U2-12	Output Terminal Status at Fault (Output Term Sts)	—	—	Displays the same status as the U1-11.	—	Q	Q	Q	Q
	U2-13	Operation Status at Fault (Inverter Status)	—	—	Displays the same status as the U1-12.	—	Q	Q	Q	Q
	U2-14	Elapsed Operation Time at Fault (Elapsed Time)	1 hour	—	—	—	Q	Q	Q	Q

Function	Parameter No.	Name (Digital Operator Display)	Min. Unit	Description	Analog Monitor Output Level	Parameter Access Level			
						V/f	V/f w/ PG	Vector w/o PG	Vector w/ PG
Function U3 Fault History	U3-01	Most Recent Fault (Last Fault)	—	—	—	Q	Q	Q	Q
	U3-02	Second Most Recent Fault (Fault Message 2)	—	—	—	Q	Q	Q	Q
	U3-03	Third Most Recent Fault (Fault Message 3)	—	—	—	Q	Q	Q	Q
	U3-04	Fourth/oldest Fault (Fault Message 4)	—	—	—	Q	Q	Q	Q
	U3-05	Elapsed Operation Time at Fault (Elapsed Time 1)	1 hour	—	—	Q	Q	Q	Q
	U3-06	Elapsed Time of Second Fault (Elapsed Time 2)	1 hour	—	—	Q	Q	Q	Q
	U3-07	Elapsed Time of Third Fault (Elapsed Time 3)	1 hour	—	—	Q	Q	Q	Q
	U3-08	Elapsed Time of Fourth/oldest Fault (Elapsed Time 4)	1 hour	—	—	Q	Q	Q	Q

A.3 VS-616G5 Parameters

Function	Parameter No.	Name (Digital Operator Display)	Setting Range	Setting Unit	Factory Setting	Remarks (Digital Operator Display)	Change during Operation o: Enabled x: Disabled	Parameter Access Level				User Setting	
								V/f	V/f w/ PG	Open Loop Vector	Flux Vector		
Initialize	Initialization	A1-00	Language Selection (Select Language)	0.1	1	1 (Note1)	0: English 1: Japanese 2: Deutsch <1110> 3: Francais <1110> 4: Italiano <1110> 5: Espanol <1110> 6: Portugues <1110>	o	Q	Q	Q	Q	
		A1-01	Access Level (Access Level)	0~4	1	2	0: Operation Only 1: User Level (Note 5) 2: Quick-Start [Q] 3: Basic Level [B] 4: Advanced Level [A]	o	Q	Q	Q	Q	
		A1-02	Control Method Selection (Control method)	0~3	1	0 (Note1)	0: V/F Control 1: V/F w/PG Fdbk 2: Open Loop Vector 3: Flux Vector	x	Q	Q	Q	Q	
		A1-03	Initialize (Init Parameters)	0 1110 2220 3330	N/A	0	0 : No Initialize 1110: User Initialize (Note 7) 2220: 2-Wire Initialize 3330: 3-Wire Initialize	x	Q	Q	Q	Q	
		A1-04	Password 1 * (Enter Password)	0000~ 9999	1	0000	Password protection for: A1-01 Access Level A1-02 Control Method A1-03 Initialization A2-01 to A2-32 User Parameters (If selected)	x	Q	Q	Q	Q	
User Parameters	A2-01 ~ A2-32	User Setting Parameters (Function A2)	—	—	—	User Parameter 1 to User Parameter 32	x	A	A	A	A		
Note 1	Not initialized. (Domestic standard specifications: A1-01 = 1, A1-02 = 2)												
Note 2	Setting range is only 0 and 1 when the control method is set to flux vector control (A1-02 = 3)												
Note 5	Selection "1: User Level" is only available after selecting setting 4: Advanced Level and then entering a user parameter in A2-01.												
Note 7	Setting 1110: User Initialize is only available after setting Parameter No. 02-03 to 1.												

Function	Parameter No.	Name (Digital Operator Display)	Setting Range	Setting Unit	Factory Setting	Remarks (Digital Operator Display)	Change during Operation o: Enabled x: Disabled	Parameter Access Level				User Setting
								V/f	V/f w/ PG	Open Loop Vector	Flux Vector	
Group B Application Function b1 Sequence	B1-01	Reference Selection (Reference Source)	0 ~ 4	1	1	0: (Operator) 1: (Terminals) 2: Communication (Serial Com) 3: (Option PCB) 4: (EWS) Reference from CP-717 <1110>(Note 8)	x	Q	Q	Q	Q	
	B1-02	Operation Method Selection (Run Source)	0 ~ 4	1	1	0: (Operator) 1: (Terminals) 2: Communication(Serial Com) 3: (Option PCB) 4: (EWS) Run from CP-717 <1110> (Note 8)	x	Q	Q	Q	Q	
	B1-03	Stopping Method Selection (Stopping Method)	0 ~ 3 (Note 2)	1	0	0: (Ramp to Stop) 1: (Coast to Stop) 2: DC injection to stop (DCInj to Stop) 3: Coast to stop with timer (Coast w/Timer)	x	Q	Q	Q	Q	
	B1-04	Reverse Operation Prohibit (Reverse Oper)	0, 1	1	0	0: (Reverse Enabled) 1: (Reverse Disabled)	x	B	B	B	B	
	B1-05	Operation Selection for Setting of E1-09 or less (Zero-Speed Oper)	0 ~ 3	1	0	0: Run at frequency reference (Run at Freq Ref) 1: (STOP) 2: Run at minimum frequency (RUN at Min Freq) 3: (RUN at Zero RPM)	x	-	-	-	A	
	B1-06	Digital Input Scan Time (Cntl Input Scans)	0, 1	1	1	0: (2 mS - 2 Scans) 1: (5 mS - 2 Scans)	x	A	A	A	A	
	B1-07	Operation selection after switching to remote mode (LOC/REM RUN Sel) (Note 9)	0, 1	1	0	0: Cycle external run (Cycle Extern RUN) 1: Accept external run (Accept Extern RUN)	x	A	A	A	A	
	B1-08 <1110>	Run command acceptance while being programmed (RUN CMD at PRG)	0, 1	1	0	0: Disabled 1: Enabled	x	A	A	A	A	

Note 2 Setting range is only 0 and 1 when the control method is set to flux vector control (A1-02 = 3)

Note 8 (Tentative) Setting parameter B1-01 or B1-02 to 4 allows reference and/or run source from CP-717 when either CP-916 or CP-216 option cards are installed.

Note 9 Drive can be switched between local and remote mode while continuing to run. When switching from remote to local the last remote speed command will be set as the local speed for a bumpless transition.

Function	Parameter No.	Name (Digital Operator Display)	Setting Range	Setting Unit	Factory Setting	Remarks (Digital Operator Display)	Change during Operation o: Enabled x: Disabled	Parameter Access Level				User Setting
								V/f	V/f w/ PG	Open Loop Vector	Flux Vector	
Function b2 DC Injection Brake	B2-01	DC Injection Braking Starting Frequency (DCInj Start Freq)	0.0~10.0	0.1Hz	0.5	—	x	B	B	B	B	
	B2-02	DC Injection Current (DCInj Current)	0~100	1%	50	—	x	B	B	B	-	
	B2-03	DC Injection Time at Start (DCInj Time @Start)	0.00~10.00	0.01s	0.00	—	x	B	B	B	B	
	B2-04	DC Injection Braking Time at Stop (DCInj Time @Stop)	0.00~10.00	0.01s	0.50 *	* When 02-09 = 1 (American), the setting is 0.00s. <24>	x	B	B	B	B	
	B2-08 <1110>	Magnetic Flux Compensation Capacity (FieldComp)	0~500	1%	0	100% is no-load current value at Min. frequency (E1-09)	x	-	-	A	A	
Speed Search	B3-01	Speed Search Selection at Start (SpdSrch at Start)	0,1	1	0*	0: Disabled 1: Enabled * Factory setting defaults to 0: Disabled except when (A1-02=1) (V/F w/PG Fdbk) or 3 (Flux Vector).	x	A	A	A	A	
	B3-02	Speed Search Operation Current (SpdSrch Current)	0~200	1%	150*	* Factory setting defaults to 150 when A1-02=0 (V/F Control). When A1-02=2 (Open Loop Vector), the default is 100.	x	A	-	A	-	
	B3-03	Speed Search Deceleration Time (SpdSrch Dec Time)	0.1~10.0	0.1s	2.0	—	x	A	-	A	-	
Delay Timers Brake Sequence	B4-01	Timer Function On-delay Time (Delay-ON Timer)	0.0~300.0	0.1s	0.0	—	x	A	A	A	A	
	B4-02	Timer Function Off-delay Time (Delay-OFF Timer)	0.0~300.0	0.1s	0.0	—	x	A	A	A	A	

Function	Parameter No.	Name (Digital Operator Display)	Setting Range	Setting Unit	Factory Setting	Remarks (Digital Operator Display)	Change during Operation o: Enabled x: Disabled	Parameter Access Level				User Setting
								V/f	V/f w/ PG	Open Loop Vector	Flux Vector	
Group b Application Function b5 PID Control	B5-01	PID Control Mode Selection (PID Mode)	0 ~ 4	1	0	0: (Disabled) 1: (Enabled D=Fdbk) 2: Enabled D = Feed-Forward (Enabled D=Fdfwd) 3: Reference = Frequency Reference + PID Output (Fref+PID D=Fdbk) 4: Reference = Frequency Reference + PID Output D is feed-forward (Fref+PID D=Fdfwd)	x	A	A	A	A	
	B5-02	Proportional Gain (P) (PID Gain)	0.00~25.00	0.01	1.00	—	o	A	A	A	A	
	B5-03	Integral (I) Time (PID I Time)	0.0~360.0	0.1s	1.0	—	o	A	A	A	A	
	B5-04	Integral (I) Limit (PID I Limit)	0.0~100.0	0.1%	100	—	o	A	A	A	A	
	B5-05	Derivative (D) Time (PID D Time)	0.00~10.00	0.01s	0.00	—	o	A	A	A	A	
	B5-06	PID Limit (PID Limit)	0.00~100.0	0.1%	100.0	—	o	A	A	A	A	
	B5-07	PID Offset Adjustment (PID Offset)	-100.0~+100.0	0.1%	0.0	—	o	A	A	A	A	
	B5-08	PID Primary Delay Time (PID Delay Time)	0.00~10.00	0.01s	0.00	—	o	A	A	A	A	
	B5-09 <1110>	PID Output Selection (Output Level Sel)	0, 1	1	0	0: PID Forward Output [X 1] (Normal Character) 1: PID Reverse Output [X-1] (Rev Character)	x	A	A	A	A	
	B5-10 <1110>	PID Output Gain (Output Gain)	0.0 ~ 25.0	.1	1.0	—	x	A	A	A	A	
	B5-11 <1110>	PID Output Reverse Selection (Output Rev Sel)	0, 1	1	0	0: When PID output is negative, motor direction is not changed, PID output is limited to 0. (0 limit) 1: When PID output is negative, motor reverses direction. (Reverse)	x	A	A	A	A	

Function	Parameter No.	Name (Digital Operator Display)	Setting Range	Setting Unit	Factory Setting	Remarks (Digital Operator Display)	Change during Operation o: Enabled x: Disabled	Parameter Access Level				User Setting	
								V/f	V/f w/ PG	Open Loop Vector	Flux Vector		
Group b Application	PID Control	B5-12 <1110>	PID Feedback Reference Missing Detection Selection (Fb Los Det Sel)	0~2	1	0	0: PID feedback missing detection disabled. (Disabled) 1: PID feedback missing detection enabled. (Alarm) Operation continues after detection, "Fbl" alarm is displayed. 2: PID feedback missing detection enabled. (Fault) Inverter output is shut off after detection, "Fbl" is displayed.	x	A	A	A	A	
		B5-13 <1110>	PID Feedback Reference Missing Detection Level (Fb los Det Lvl)	0~100	1%	0	—	x	A	A	A	A	
		B5-14 <1110>	PID Feedback Reference Missing Detection Time (Fb los Det Time)	0.0~25.5	0.1s	1.0	—	x	A	A	A	A	
	Function b6 Reference Hold	B6-01	Dwell Frequency at Start (Dwell Ref @Start)	0.0~400.0	0.1Hz	0.0	—	x	A	A	A	A	
		B6-02	Dwell Time at Start (Dwell Time @ Start)	0.0~10.0	0.1s	0.0	—	x	A	A	A	A	
		B6-03	Dwell Frequency at Stop (Dwell Ref @ Stop)	0.0~400.0	0.1Hz	0.0	—	x	A	A	A	A	
		B6-04	Dwell Time at Stop (Dwell Time @ Stop)	0.0~10.0	0.1s	0.0	—	x	A	A	A	A	
	Function b7 Droop Control	B7-01	Droop Control Gain (Droop Quantity)	0.0~100.0	0.1%	0.0	—	o	-	-	-	A	
		B7-02	Droop Control Delay Time (Droop Delay Time)	0.03~2.00	0.01s	0.05	—	o	-	-	-	A	

Function	Parameter No.	Name (Digital Operator Display)	Setting Range	Setting Unit	Factory Setting	Remarks (Digital Operator Display)	Change during Operation o: Enabled x: Disabled	Parameter Access Level				User Setting	
								V/f	V/f w/ PG	Open Loop Vector	Flux Vector		
Group b Application	Function b8 Energy Saving	B8-01	Energy-saving Gain (Energy Save Gain)	0~100	1%	80	—	x	A	A	-	-	
		B8-02	Energy-saving Frequency (Energy Save Freq)	0.0~400.0	0.1Hz	0.0	—	x	A	A	-	-	
		B8-03 <1110>	Energy -saving Mode Selection	0, 1	1	0	0: (Disabled) 1: (Enabled)	x	-	-	F (A) Note	F (A) Note	
		B8-04 <1110>	Energy-saving Control Gain (Energy Save Gain)	0.0~10.0	0.1	0.7*	*When control mode A1-02 = 3, default factory setting becomes 1.0	o	-	-	F (A) Note	F (A) Note	
		B8-05 <1110>	Energy-saving Control Time Constant (Energy Save F.T)	0.00~10.00	0.01s	0.50*	*When control mode A1-02 = 3, default factory setting becomes .01	o	-	-	F (A) Note	F (A) Note	
	Zero Servo	B9-01	Zero-servo gain (Zero Servo Gain)	0~100	1	5	—	x	-	-	-	A	
		B9-02	Zero-servo Completion Width (Zero Servo Count)	0~16383	1	10	—	x	-	-	-	A	
							Note: USA (02x09=1) and EUR. (02x09=2) are Advanced, others are Factory setting.						

Function	Parameter No.	Name (Digital Operator Display)	Setting Range	Setting Unit	Factory Setting	Remarks (Digital Operator Display)	Change during Operation o: Enabled x: Disabled	Parameter Access Level				User Setting
								V/f	V/f w/ PG	Open Loop Vector	Flux Vector	
Group C Tuning Function C1 Accel / Decel	C1-01	Acceleration Time 1 (Accel Time 1)	Depends on C1-10 0.00~600.00 or 0.0 ~ 6000.0	Depends on C1-10 0.01s or 0.1s	10.0	—	o	Q	Q	Q	Q	
	C1-02	Deceleration Time 1 (Decel Time 1)			10.0	—	o	Q	Q	Q	Q	
	C1-03	Acceleration Time 2 (Accel Time 2)			10.0	—	o	B	B	B	B	
	C1-04	Deceleration Time 2 (Decel Time 2)			10.0	—	o	B	B	B	B	
	C1-05	Acceleration Time 3 (Accel Time 3)			10.0	—	x	A	A	A	A	
	C1-06	Deceleration Time 3 (Decel Time 3)			10.0	—	x	A	A	A	A	
	C1-07	Acceleration Time 4 (Accel Time 4)			10.0	—	x	A	A	A	A	
	C1-08	Deceleration Time 4 (Decel Time 4)			10.0	—	x	A	A	A	A	
	C1-09	Emergency Stop Time (Fast Stop Time)			10.0	—	x	B	B	B	B	
	C1-10	Accel/Decel Time Set Unit (Acc/Dec Units)	0.1	1	1	0: Set unit of accel/decel time is 0.01s. (0.01 Seconds) 1: Set unit of accel/decel time is 0.1s. (0.1 Seconds)	x	A	A	A	A	
	C1-11	Accel/Decel Time Switching Frequency (Acc/Dec SW Freq)	0.0~400.0	0.1Hz	0.0	—	x	A	A	A	A	

Function	Parameter No.	Name (Digital Operator Display)	Setting Range	Setting Unit	Factory Setting	Remarks (Digital Operator Display)	Change during Operation o: Enabled x: Disabled	Parameter Access Level				User Setting	
								V/f	V/f w/ PG	Open Loop Vector	Flux Vector		
Group C Tuning	Function C2 S-Curve Acc/Dec	C2-01	S-Curve Characteristic Time at Acceleration Start (SCrv Acc@ Start)	0.00~2.50	0.01s	0.20	—	x	A	A	A	A	
		C2-02	S-Curve Characteristic Time at Acceleration End (SCrv Acc@ End)	0.00~2.50	0.01s	0.20	—	x	A	A	A	A	
		C2-03	S-Curve Characteristic Time at Deceleration Start (SCrv Dec @ Start)	0.00~2.50	0.01s	0.20	—	x	A	A	A	A	
	Function C3 Motor Slip Compensation	C3-01	Slip Compensation Gain (Slip Comp Gain)	0.0~2.5	0.1	1.0*	* Default factory setting is 0.0 when A1-02=0 [V/F mode]. When A1-02=2 [Open Loop Vector] or 3 [Flux Vector] default factory setting is 1.0	o	B	-	B	B	
		C3-02	Slip Compensation Primary Delay Time (Slip Comp Time)	0~10000	1 ms	200*	* Default factory setting is 2000ms when A1-02=0 [V/F mode]. When A1-02=2 [Open Loop Vector] default factory setting is 200ms.	x	A	-	A	-	
		C3-03	Slip Compensation Limit (Slip Comp Limt)	0~250	1%	200	—	x	A	-	A	-	
		C3-04	Slip Compensation Selection during Regeneration (Slip Comp Regen)	0, 1	1	0	0 : Disabled 1 : Enabled	x	A	-	A	-	
		C3-05 <1110>	Flux Calculation Method (Flux Select)	0, 1	1	0	0 : Magnetic flux is calculated by output frequency after compensation. (Slip Included) 1 : Magnetic flux is calculated by output frequency before compensation. (Slip Excluded)	x	-	-	A	-	
		C3-06 <1110>	Output Voltage Limit Operation Selection (Output V limit)	0, 1	1	0	0 : Disabled (Note 10) 1 : Enabled (Note 11)	x	-	-	A	A	
Note 10	When this parameter is "0" slip compensation will be disabled when the motor is operating above its base speed. The motor voltage will not be reduced above base speed.												
Note 11	Open Loop Vector: When this parameter is set to "1" the motor voltage will be reduced slightly when the motor is operating above 90% base speed. Slip Compensation is enabled. Speed control accuracy is improved. This may prevent speed instabilities due to motor voltage saturation. This setting may improve speed regulation however motor torque/amp will be reduced by up to 10% due to motor voltage reduction above base speed. Flux Vector: Torque linearity is improved.												

Function	Parameter No.	Name (Digital Operator Display)	Setting Range	Setting Unit	Factory Setting	Remarks (Digital Operator Display)	Change during Operation: o: Enabled x: Disabled	Parameter Access Level				User Setting	
								V/f	V/f w/ PG	Open Loop Vector	Flux Vector		
Group C Tuning	Function C4 Torque Compensation	C4-01	Torque Compensation Gain (Torq Comp Gain)	0.00~2.50	0.01	1.00	—	o	B	B	B	-	
		C4-02	Torque Compensation Time (Torq Comp Time)	0~10000	1 ms	20*	* When A1-02=2 [Open Loop Vector] factory default setting is 20 ms. When A1-02=1 or 3 [V/F or V/F w/PG] factory default setting is 200 ms.	x	A	A	A	-	
		C4-03 <1110>	Forward Torque Compensation Value @ Start (F TorqCmp @start)	0.0~200.0	0.1%	0.0	Functions only when starting a motor. Torque reference and motor flux can be ramped up quickly to improve speed response during start. A setting of 0.0 disables this feature.	x	-	-	A	-	
		C4-04 <1110>	Reverse Torque Compensation Value @ Start. (R TorqCmp @ start)	200.0~0.0	0.1%	0.0	Functions only when starting a motor. Torque reference and motor flux can be ramped up quickly to improve speed response during start. A setting of 0.0 disables this feature.	x	-	-	A	-	
		C4-05 <1110>	Torque Compensation Time Constant (TorqCmp Delay T)	0~200	1ms	10	When 0~4ms is set, it is operated without filter. Functions with C4-03 and C4-04.	x	-	-	A	-	
	Function C5 ASR Tuning	C5-01	ASR Proportional (P) Gain 1 (ASR P Gain 1)	0.00~300.00	0.01	20.00*	When A1-02=1 [V/f w/PG] factory default setting is .20. When A1-02=3 factory default setting is 20.00.	o	-	B	-	B	
		C5-02	ASR Integral (I) Time 1 (ASR 1 Time 1)	0.000~10.000	0.001s	0.500*	When A1-02=1 [V/f w/PG] factory default setting is .200. When A1-02=3 factory default setting is .500	o	-	B	-	B	
		C5-03	ASR Proportional (P) Gain 2 (ASR P Gain 2)	0.00~300.00	0.01	20.00*	When A1-02=1 [V/f w/PG] factory default setting is .02 When A1-02=3 factory default setting is 20.00.	o	-	B	-	B	
		C5-04	ASR Integral (I) Time 2 (ASR 1 Time 2)	0.000~10.000	0.001s	0.500*	When A1-02=1 [V/f w/PG] factory default setting is .050. When A1-02=3 factory default setting is .500.	o	-	B	-	B	
		C5-05	ASR Limit (ASR Limt)	0.0~20.0	0.1%	5.0	—	x	-	A	-	-	
		C5-06	ASR Primary Delay Time (ASR Delay Time)	0.000~0.500	0.001s	0.004	—	x	-	-	-	A	
		C5-07	ASR Switching Frequency (ASR Gain SW Freq)	0.0~400.0	0.1Hz	0.0	—	x	-	-	-	A	
		C5-08	ASR Integral Limit (ASR I Limit)	0~400	1	400%	—	x	-	-	-	A	

Function	Parameter No.	Name (Digital Operator Display)	Setting Range	Setting Unit	Factory Setting	Remarks (Digital Operator Display)	Change during Operation o: Enabled x: Disabled	Parameter Access Level				User Setting	
								V/f	V/f w/ PG	Open Loop Vector	Flux Vector		
Group C Tuning	Function C6 Carrier Frequency	C6-01	Carrier Frequency Upper Limit (Carrier Freq Max)	0.4~15.0**	0.1 kHz	15.0**	When control mode is vector control (A1-02=2, 3), the setting range of C6-01 and C6-02 is 2.0~15.0. ** Setting range and factory setting differ depending on inverter capacity.	x	B	B	B	B	
		C6-02	Carrier Frequency Lower Limit (Carrier Freq Min)	0.4~15.0	0.1 kHz	15.0**		x	A	A	-	-	
		C6-03	Carrier Frequency Proportional Gain (Carrier Freq Gain)	00~99**	1	00**		x	A	A	-	-	
	Function C7 Hunting Prevention	C7-01	Hunting Prevention Selection (Hunt Prev Select)	0, 1	1	1	0: Disabled 1: Enabled	x	A	A	-	-	
		C7-02	Hunting Prevention Gain (Hunt Prev Gain)	0.00~2.50	0.01	1.00	—	x	A	A	-	-	
Group C Tuning	Function C8 Factory Tuning	C8-08	AFR Gain (AFR Gain)	0.00~10.00	0.01	1.00	—	x	-	-	A	-	
		C8-09	AFR Time Constant (AFR Time)	0~2000	1 ms	50	—	x	-	-	A	-	
		C8-30 <1110>	Carrier Frequency Selection during Auto-tuning (Carrier in tune)	0~2	1	0	0: Carrier frequency is 2 kHz. 1: Carrier frequency depends on C6-01. 2: Carrier frequency is 5 kHz. (185~300 kW: 2.5 kHz)	x	-	-	A	A	

Function	Parameter No.	Name (Digital Operator Display)	Setting Range	Setting Unit	Factory Setting	Remarks (Digital Operator Display)	Change during Operation o: Enabled x: Disabled	Parameter Access Level				User Setting	
								V/f	V/f w/ PG	Open Loop Vector	Flux Vector		
Group d Reference	Function d1 Preset Reference	D1-01	Frequency Reference 1 (Reference 1)	0.00~400.00	0.01Hz	0.00	—	o	Q	Q	Q	Q	
		D1-02	Frequency Reference 2 (Reference 2)	0.00~400.00	0.01Hz	0.00	—	o	Q	Q	Q	Q	
		D1-03	Frequency Reference 3 (Reference 3)	0.00~400.00	0.01Hz	0.00	—	o	Q	Q	Q	Q	
		D1-04	Frequency Reference 4 (Reference 4)	0.00~400.00	0.01Hz	0.00	—	o	Q	Q	Q	Q	
		D1-05	Frequency Reference 5 (Reference 5)	0.00~400.00	0.01Hz	0.00	—	o	B	B	B	B	
		D1-06	Frequency Reference 6 (Reference 6)	0.00~400.00	0.01Hz	0.00	—	o	B	B	B	B	
		D1-07	Frequency Reference 7 (Reference 7)	0.00~400.00	0.01Hz	0.00	—	o	B	B	B	B	
		D1-08	Frequency Reference 8 (Reference 8)	0.00~400.00	0.01Hz	0.00	—	o	B	B	B	B	
		D1-09	Jog Frequency Reference (Jog Reference)	0.00~400.00	0.01Hz	6.00	—	o	Q	Q	Q	Q	
	Function d2 Reference Limits	D2-01	Frequency Reference Upper Limit (Ref Upper Limit)	0.0~110.0	0.1%	100.0	—	x	B	B	B	B	
		D2-02	Frequency Reference Lower Limit (Ref Lower Limit)	0.0~109.0	0.1%	0.0	—	x	B	B	B	B	
	Function d3 Jump Frequencies	D3-01	Jump Frequency 1 (Jump Freq 1)	0.0~400.0	0.1Hz	0.0	—	x	B	B	B	B	
		D3-02	Jump Frequency 2 (Jump Freq 2)	0.0~400.0	0.1Hz	0.0	—	x	B	B	B	B	
D3-03		Jump Frequency 3 (Jump Freq 3)	0.0~400.0	0.1Hz	0.0	—	x	B	B	B	B		
D3-04		Jump Frequency Width (Jump Bandwidth)	0.0~20.0	0.1Hz	1.0	—	x	B	B	B	B		

Function	Parameter No.	Name (Digital Operator Display)	Setting Range	Setting Unit	Factory Setting	Remarks (Digital Operator Display)	Change during Operation o: Enabled x: Disabled	Parameter Access Level				User Setting	
								V/f	V/f w/ PG	Open Loop Vector	Flux Vector		
Group d Reference	Function d4 Sequence	D4-01	Frequency Reference Hold Function Selection (MOP Ref Memory)	0, 1	1	0	0: (Disabled) No hold frequency is memorized. 1: (Enabled) Hold frequency is memorized.	x	A	A	A	A	
		D4-02	±Speed Limits (Trim Control Lvl)	0~100	1%	25*	*When 02-09=1 [USA], the unit is 10%. <24>	x	A	A	A	A	
	Function d5 Torque Control	D5-01	Torque Control Selection (Torq Control Sel)	0, 1	1	0	0: (Speed Control) 1: (Torque Control)	x	-	-	-	A	
		D5-02	Torque Reference Delay Time (Torque Ref Filter)	0~1000	1 ms	0	—	x	-	-	-	A	
		D5-03	Speed Limit Selection (Speed Limit Sel)	1, 2	1	1	1: (Analog Input) terminal 13, 14 2: (Program Setting)	x	-	-	-	A	
		D5-04	Speed Limit (Speed Lmt Value)	-120 ~ +120	1%	0	—	x	-	-	-	A	
		D5-05	Speed Limit Bias (Speed Lmt Bias)	0~120	1%	10	—	x	-	-	-	A	
D5-06	Speed/torque Control Switching Timer (Ref Hold Time)	0~1000	1 ms	0	—	x	-	-	-	A			

Function	Parameter No.	Name (Digital Operator Display)	Setting Range	Setting Unit	Factory Setting	Remarks (Digital Operator Display)	Change during Operation o: Enabled x: Disabled	Parameter Access Level				User Setting
								V/f	V/f w/ PG	Open Loop Vector	Flux Vector	
Group E Motor Function E1 V/F Pattern	E1-01	Input Voltage Setting (Input Voltage)	155~255 (Note 13)	1 V	200 (Note 13)	*When 02-09=1 [USA], the value is 1.15 times of Japanese spec., which is 230/200	x	Q	Q	Q	Q	
	E1-02	Motor Selection (Motor Selection)	0, 1, 2	1	0	0: (Std Fan-Cooled) 1: (Std Blower-Cooled) 2: (Vector Motor) <1110>	x	Q	Q	Q	Q	
	E1-03	V/f Pattern Selection (V/F Selection)	00~0F	1	0F	V/f pattern selection 0: 50Hz 1: 60Hz Saturation 2: 50Hz Saturation 3: 72Hz 4: 50Hz Variable Torque 1 5: 50Hz Variable Torque 1 6: 60Hz Variable Torque 1 7: 60Hz Variable Torque 2 8: 50Hz High Starting Torque 1 9: 50Hz High Starting Torque 2 A: 60Hz High Starting Torque 1 B: 60Hz High Starting Torque 2 C: 90Hz D: 120Hz E: 180Hz F: User-defined V/f pattern	x	Q	Q	Q	Q	
	E1-04	Max. Output Frequency (Max Frequency)	40.0~400.0	0.1Hz	60.0* (Note 13)	*Factory setting differs depending on the inverter capacity 02-04. When 02-09=2 [EUR.], the value is 50.0Hz.	x	Q	Q	Q	Q	
	E1-05	Max. Voltage (Max Voltage)	0.0~255.0 (Note 13)	0.1 V	200.0 (Note 13)*	*Factory setting differs depending on the inverter capacity (02-04). When 02-09=1 (USA), the value is 1.15 times of Japanese spec., which is 230/200	x	Q	Q	Q	Q	
Note 13: This value is for the 200V class. For 400V class, the value is twice that of 200V class. For 575V class, then modify the values by 575/200												

Function	Parameter No.	Name (Digital Operator Display)	Setting Range	Setting Unit	Factory Setting	Remarks (Digital Operator Display)	Change during Operation o: Enabled x: Disabled	Parameter Access Level				User Setting	
								V/f	V/f w/ PG	Open Loop Vector	Flux Vector		
Group E Motor	Torque Control	E1-06	Max. Voltage Frequency (Base Frequency)	0.0~400.0	0.1Hz	60.0* (Note 13)	*Factory setting differs depending on the inverter capacity (02-04). When 02-09=2 (EUR.), the value is 50.0Hz.	x	Q	Q	Q	Q	
		E1-07	Mid. Output Frequency (Mid Frequency A)	0.0~400.0	0.1Hz	3.0* (Note 13)	*Factory setting differs depending on the inverter capacity (02-04). When 02-09=2 (EUR.), A1-02=0, and E1-03=OF, the value is 5/6 times that of Japan spec.[for a V/F pattern with a 50Hz base frequency]	x	Q	Q	A	F	
		E1-08	Mid. Output Frequency Voltage (Mid Voltage A)	0.00~255.0 (Note 13)	0.1 V	11.0 (Note 13)*	*Factory setting differs depending on the inverter capacity (02-04). When 02-09=1 (USA), the value is 1.15 times of Japanese spec., which is 230/200 .	x	Q	Q	A	F	
		E1-09	Min. Output Frequency (Min Frequency)	0.0~400.0	0.1Hz	0.5* (Note 13)	*Factory setting differs depending on the inverter capacity (02-04). When 02-09=2 (EUR.), A1-02=0, and E1-03=OF, the value is 5~6 times of Japan.	x	Q	Q	Q	A	
		E1-10	Min. Output Frequency Voltage (Min Voltage)	0.0~255.0 (Note 13)	0.1V	2.0 (Note 13)*	*Factory setting differs depending on the inverter capacity (02-04). When 02-09=1 (USA), the value is 1.15 times of Japanese spec., which is 230/200.	x	Q	Q	A	F	
		E1-11	Mid. Output Frequency 2 (Mid Frequency B)	0.0~400.0	0.1Hz	0.0	—	x	A	A	A	A	
		E1-12	Mid. Output Frequency Voltage 2 (Mid Voltage B)	0.0~255.0 (Note 13) *	0.1V	0.0	*When 02-09=1 (USA), the value is 1.15 times of Japanese spec., which is 230/200.	x	A	A	A	A	
		E1-13	Base Voltage (Base Voltage)	0.0~255.0 (Note 13)	0.1V	200.0 (Note 13) *	*When 02-09=1 (USA), the value is 1.15 times of Japanese spec., which is 230/200.	x	A	A	Q	Q	
		Note 13: This value is for the 200V class. For 400V class, the value is twice that of 200V class. For 575V class, then modify the values by 575/200											

Function	Parameter No.	Name (Digital Operator Display)	Setting Range	Setting Unit	Factory Setting	Remarks (Digital Operator Display)	Change during Operation o: Enabled x: Disabled	Parameter Access Level				User Setting
								V/f	V/f w/ PG	Open Loop Vector	Flux Vector	
Group E Motor Function E2 Motor Setup	E2-00	Motor Rated (Motor Rated)	—	—	—	* When inverter capacity is 7.5 kW or less, min. setting unit becomes 0.01 A. ** Factory setting differs depending on inverter capacity (02-04).	x	-	-	-	-	
	E2-01	Motor Rated Current (Motor Rated FLA)	0.1~1500.0	0.1A*	1.9**		x	Q	Q	Q	Q	
	E2-02	Motor Rated Slip (Motor Rated Slip)	0.00~20.00	0.01Hz	2.90**		x	A	A	Q	Q	
	E2-03	Motor No-load Current (No-Load Current)	0.00~1500.0	0.01A*	1.20**		x	A	A	Q	Q	
	E2-04	Number of Motor Poles (Number of Poles)	2~48	1 pole	4		x	-	Q	-	Q	
	E2-05	Motor Line-to-line Resistance (Term Resistance)	0.000~65.000	0.001 W	9.842**		x	A	A	A	A	
	E2-06	Motor Leak Inductance (Leak Inductance)	0.0~30.0	0.1%	18.2**		x	-	-	A	A	
	E2-07	Motor Iron-core Saturation Coefficient 1 (Saturation Comp 1)	0.00~0.50	0.01	0.50	—	x	-	-	A	A	
	E2-08	Motor Iron-core Saturation Coefficient 2 (Saturation Comp 2)	0.00~0.75	0.01	0.75	—	x	-	-	A	A	
	E2-09	Motor Mechanical Loss (Mechanical Loss)	0.0~10.0	0.1%	0.0	—	x	-	-	-	A	
	E2-10	Motor Iron Loss of Torque Compensation (Tcomp Iron Loss)	0~65535	1W	14	Access level is changed from F to A. <1110>	x	A	A	-	-	

Function	Parameter No.	Name (Digital Operator Display)	Setting Range	Setting Unit	Factory Setting	Remarks (Digital Operator Display)	Change during Operation o: Enabled x: Disabled	Parameter Access Level				User Setting	
								V/f	V/f w/ PG	Open Loop Vector	Flux Vector		
Group E Motor	Function E3 Control Method	E3-01	Motor 2 Control Method Selection (Control Method)	0~3	1	2	0: (V/F Control) 1: (V/F w/PG Fdbk) 2: (Open Loop Vector) 3: (Flux Vector)	x	A	A	A	A	
	Function E4 V/F Pattern 2	E4-01	Motor 2 Max. Output Frequency (Max Frequency)	40.0~400.0	0.1Hz	60.0	—	x	A (Note 14)	A (Note 14)	A (Note 14)	A (Note 14)	
		E4-02	Motor 2 Max. Voltage (Max Voltage)	0.0~255.0 (Note 13)	0.1V	200.0 (Note 13)	—	x	A (Note 14)	A (Note 14)	A (Note 14)	A (Note 14)	
		E4-03	Motor 2 Max. Voltage Frequency (Base Frequency)	0.0~400.0	0.1Hz	60.0	—	x	A (Note 14)	A (Note 14)	A (Note 14)	A (Note 14)	
		E4-04	Motor 2 Mid. Output Frequency 1 (Mid Frequency)	0.00~400.0	0.1Hz	3.0*	* Factory setting differs depending on the control method [E3-01]	x	A (Note 14)	A (Note 14)	A (Note 14)	F (Note 14)	
		E4-05	Motor 2 Mid. Output Frequency Voltage 1 (Mid Voltage)	0.0~255.0 (Note 13)	0.1V	11.0 (Note 13)*	* Factory setting differs depending on the control method [E3-01]	x	A (Note 14)	A (Note 14)	A (Note 14)	F (Note 14)	
		E4-06	Motor 2 Min. Output Frequency (Min Frequency)	0.0~400.0	0.1Hz	0.5*	* Factory setting differs depending on the control method [E3-01]	x	A (Note 14)	A (Note 14)	A (Note 14)	A (Note 14)	
		E4-07	Motor 2 Min. Output Frequency Voltage (Min Voltage)	0.0~255.0 (Note 13)	0.1V	2.0* (Note13)	* Factory setting differs depending on the control method [E3-01]	x	A (Note 14)	A (Note 14)	A (Note 14)	F (Note 14)	
Note 13: This value is for the 200V class. For 400V class, the value is twice that of 200V class. For 575V class, then modify the values by 575/200 Note 14: Control mode is determined by E3-01.													

Function	Parameter No.	Name (Digital Operator Display)	Setting Range	Setting Unit	Factory Setting	Remarks (Digital Operator Display)	Change during Operation o: Enabled x: Disabled	Parameter Access Level				User Setting
								V/f	V/f w/ PG	Open Loop Vector	Flux Vector	
Group E Motor Function E5 Motor Setup 2	E5-01	Motor 2 Rated Current (Motor Rated FLA)	0.00~1500.0	0.1A*	1.9**	* Setting unit is 0.01A for models of 7.5 kW or less. ** Factory setting differs depending on inverter capacity (02-04).	x	A (Note 14)	A (Note 14)	A (Note 14)	A (Note 14)	
	E5-02	Motor 2 Rated Slip (Motor Rated Slip)	0.00~20.00	0.01Hz	2.90**		x	A (Note 14)	A (Note 14)	A (Note 14)	A (Note 14)	
	E5-03	Motor 2 No-load Current (No-Load Current)	0.00~1500.0	0.01A*	1.20**		x	A (Note 14)	A (Note 14)	A (Note 14)	A (Note 14)	
	E5-04	Motor 2 Number of poles (Motor 2 # Poles)	2~48	1 pole	4		x	- (Note 14)	A (Note 14)	- (Note 14)	A (Note 14)	
	E5-05	Motor 2 Line-to-line Resistor (Motor 2 term Ohms)	0.000~65.000	0.001 W	9.842**		x	A (Note 14)	A (Note 14)	A (Note 14)	A (Note 14)	
	E5-06	Motor 2 Leak Inductance (Motor 2 Leak)	0.0~30.0	0.1%	18.2**		x	A (Note 14)	- (Note 41)	A (Note 14)	A (Note 14)	
Note 13: This value is for the 200V class. For 400V class, the value is twice that of 200V class. For 575V class, modify the values by 575/200												
Note 14: Control mode is determined by E3-01.												
Group F Options * Function F1 PG Option Setup	F1-01	PG Constant (PG Pulses/Rev)	0~60000	1	600*	*When 02-09=1 (USA), 2 (EUR.), factory setting is 1024	x	-	Q	-	Q	
	F1-02	Operation Selection at PG Open Circuit (PG Fdbk Loss Sel)	0~3	1	1	0: (Ramp to Stop) 1: (Coast to Stop) 2: (Fast-Stop) 3: (Alarm Only)	x	-	B	-	B	
	F1-03	Operation Selection at Overspeed (PG Overspeed Sel)	0~3	1	1	0: (Ramp to Stop) 1: (Coast to Stop) 2: (Fast-Stop) 3: (Alarm Only)	x	-	B	-	B	
	F1-04	Operation Selection at Deviation (PG Deviation Sel)	0~3	1	3	0: (Ramp to Stop) 1: (Coast to Stop) 2: (Fast-Stop) 3: (Alarm Only)	x	-	B	-	B	
	F1-05	PG Rotation (PG Rotation Sel)	0, 1	1	0	0: Counter-clockwise (Fwd = C.C.W.) 1: Clockwise (Fwd = C.W.)	x	-	B	-	B	
	F1-06	PG Division Rate PG --Pulse monitor (PG Output Ratio)	1~132	1	1	Effective only when control circuit board PG-B2 is used.	x	-	B	-	B	
	F1-07	Integral Value during Accel/decel Enable/disable (PG Ramp PI/I Sel)	0, 1	1	0	0: (Disabled) 1: (Enabled)	x	-	B	-	-	
	F1-08	Overspeed Detection Level (PG Overspd Level)	0~120	1%	115	—	x	-	A	-	A	
* When access level is BASIC (A1-03), constant is not displayed unless the option is connected.												

Function	Parameter No.	Name (Digital Operator Display)	Setting Range	Setting Unit	Factory Setting	Remarks (Digital Operator Display)	Change during Operation o: Enabled x: Disabled	Parameter Access Level				User Setting	
								V/f	V/f w/ PG	Open Loop Vector	Flux Vector		
Group F Options *	Function F1 PG Option Setup	F1-09	Overspeed Detection Delay Time (PG Overspd Time)	0.0~2.0	0.1s	0.0*	* When A1-02=1 [V/f w/PG] factory setting is 1.0. When A1-02=3 [Flux Vector] factory setting is 0.0.	x	-	A	-	A	
		F1-10	Excessive Speed Deviation Detection Level (PG Deviate Level)	0~50	1%	10	—	x	-	A	-	A	
		F1-11	Excessive Speed Deviation detection Delay Time (PG Deviate Time)	0.0~10.0	0.1s	0.5	—	x	-	A	-	A	
		F1-12	Number of PG Gear Teeth 1 (PG # Gear Teeth 1)	0~1000	1	0	—	x	-	A	-	-	
		F1-13	Number of PG Gear Teeth 2 (PG # Gear Teeth 2)	0~1000	1	0	—	x	-	A	-	-	
		F1-14	PGO Detection Time (PGO Detect Time)	0~10.0	0.1s	2.0	—	x	-	A	-	A	
	Function F2 AI-14 Setup	F2-01	AI-14B Card Input Selection (AI-14 Input Sel)	0, 1	1	0	0: (3-ch Individual) 1: (3ch Addition)	x	A	A	A	A	
* When access level is BASIC (A1-03), constant is not displayed unless the option is connected.													

Function	Parameter No.	Name (Digital Operator Display)	Setting Range	Setting Unit	Factory Setting	Remarks (Digital Operator Display)	Change during Operation o: Enabled x: Disabled	Parameter Access Level				User Setting
								V/f	V/f w/ PG	Open Loop Vector	Flux Vector	
Group F Options * Function F3 DI-08, 16 Setup	F3-01	Digital Input Selection (DI Input)	0~7	1	0	0: (BCD 1%) 1: (BCD 0.1%) 2: (BCD 0.01%) 3: (BCD 1Hz) 4: (BCD 0.1Hz) 5: (BCD 0.01Hz) 6: BCD Special setting 5 digit input, Binary 255/100% (BCD (5DG) 0.01Hz) 7: (Binary)* *Set value is displayed as decimal.	x	A	A	A	A	
	F4-01	Channel 1 Monitor Selection (AO Ch1 Select)	1~38	1	2	Analog Output option Channel 1 1: Frequency reference 2: Output frequency 3: Inverter output current 5: Motor speed 6: Output voltage 7: DC bus voltage 8: Output power 9: Torque reference (internal) 15: External terminal 13 input voltage 16: External terminal 14 input voltage 17: External terminal 16 input voltage 18: Motor secondary current (Iq) 19: Motor excitation current (Id) 20: Primary frequency after SFS 21: Speed controller ASR input 22: Speed controller ASR output 23: Speed deviation 24: PID feedback 26: Voltage reference (Vq output) 27: Voltage reference (Vd output) 32: ACR (q) Output 33: ACR (d) Output 36: PID Input <1110> 37: PID Output <1110> 38: PID Reference <1110>	x	A	A	A	A	
	F4-02	Channel 1 Gain (AO Ch1 Gain)	0.00~2.50	0.01	1.00	—	o	A	A	A	A	
	F4-03	Channel 2 Monitor Selection (AO Ch2 Select)	1~38	1	3	Analog Output option Channel 2 selection (same as F4-01)	x	A	A	A	A	
	F4-04	Channel 2 Gain (AO Ch2 Gain)	0.00~2.50	0.01	0.50	—	o	A	A	A	A	
	F4-05 <1110>	CH1 Output Bias (AO Ch1 Bias)	-10.0~10.0	0, 1	0.0	—	o	A	A	A	A	
	F4-06 <1110>	CH2 Output Bias	-10.0~10.0	0, 1	0.0	—	o	A	A	A	A	

* When access level is BASIC (A1-03), constant is not displayed unless the option is connected.

Function	Parameter No.	Name (Digital Operator Display)	Setting Range	Setting Unit	Factory Setting	Remarks (Digital Operator Display)	Change during Operation o: Enabled x: Disabled	Parameter Access Level				User Setting	
								V/f	V/f w/ PG	Open Loop Vector	Flux Vector		
Group F Options	Function F5 DO - 02 Setup	F5-01	Channel 1 Output Selection (DO-02 Ch1 Select)	00~37	1	0	—	x	A	A	A	A	
		F5-02	Channel 2 Output Selection (DO-02 Ch2 Select)	00~37 <26>	1	1	—	x	A	A	A	A	
	Function F6 DO - 08 Setup	F6-01	Output Mode Selection (DO-08 Selection)	0, 1	1	0	0: (8ch Individual) 1: (Binary Output)	x	A	A	A	A	
	Function F7 PO - 36F Setup	F7-01	Frequency Multiple Selection (PO-36F Selection)	0~4	1	1	0: (1 X Output Freq) 1: (6 X Output Freq) 2: (10 X Output Freq) 3: (12 X Output Freq) 4: (36 X Output Freq)	x	A	A	A	A	
	Function F8 SI - F/G Setup	F8-01	SI-F/G Communication Error Detection Operation Selection (E-15 Det Sel)	0~3	1	1	0: (Ramp to Stop) 1: (Coast to Stop) 2: (Fast - Stop) 3: (Alarm Only)	x	A	A	A	A	
	Function F9 CP-916 Setup / DDS • SI-B	F9-01	Option External Fault Selection (EFO Selection)	0, 1	1	0	0: When 1 is shown, EFO occurs (Normally Open) 1: When 0 is shown, EFO occurs. (Normally Closed)	x	A	A	A	A	
		F9-02	Option External Fault Detection Selection (EFO Detection)	0, 1	1	0	0: (Always Detected) 1: (Only During Run)	x	A	A	A	A	
		F9-03	Option External Fault Detection Operation Selection (EFO Fault Action)	0~3	1	1	0: (Ramp to Stop) 1: (Coast to Stop) 2: (Fast - Stop) 3: (Alarm Only)	x	A	A	A	A	
		F9-04	Trace Sampling Time (Trace Sample Tim)	0~60000	1	0	—	x	A	A	A	A	
		F9-05	Torque Reference/Torque Limit Selection through DP-RAM communication (Torq Ref / Lmt Sel)	0, 1	1	1	0: (Disabled) 1: (Enabled)	x	-	-	-	A	
		F9-06	DP-RAM Communication Error Detection Operation Selection (BUS Fault Sel)	0~3	1	1	0: (Ramp to Stop) 1: (Coast to Stop) 2: (Fast - Stop) 3: (Alarm Only)	x	A	A	A	A	

Function	Parameter No.	Name (Digital Operator Display)	Setting Range	Setting Unit	Factory Setting	Remarks (Digital Operator Display)	Change during Operation o: Enabled x: Disabled	Parameter Access Level				User Setting
								V/f	V/f w/ PG	Open Loop Vector	Flux Vector	
Terminal Function Function H1 Digital Inputs	H1-01	Terminal 3 Selection (Terminal 3 Sel)	00~77	1	24	Multi-function input (terminal 3) 0: 3-Wire Control 1: Local/Remote Selection 2: Option/Inverter Selection 3: Multi-Step Reference 1 4: Multi-Step Reference 2 5: Multi-Step Reference 3 6: Jog Frequency Reference 7: Multi-Accel/Decel 1 8: External Baseblock N.O. 9: External Baseblock N.C. A: Accel/Decel Ramp Hold B: OH2 Alarm Signal C: Terminal 16 Enable D: V/F Mode Select E: ASR Integral Reset F: Terminal Not Used 10: MOP Increase 11: MOP Decrease 12: Forward Jog 13: Reverse Jog 14: Fault Reset 15: Fast-Stop N.O. 16: Motor 2 Select 17: Fast Stop N.C. input <1110> 18: Timer Function 19: PID Disable 1A: Multi-Accel/Decel 2 1B: Program Lockout 1C: Trim Control Increase 1D: Trim Control Decrease 1E: Ref Sample Hold 1F: Terminal 13/14 Switch 24: External Fault 30: PID Integral Reset 31: PID Control Integral Hold <1110> 60: DC Injection Activate 61: Speed Search 1 62: Speed Search 2 63: Energy Save Mode 64: Speed Search 3 65: KEB Ridethrough N.C. 66: KEB Ridethrough N.O 71: Speed/Torque Control Change 72: Zero Servo Command 77: ASR Gain Switch	x	B	B	B	B	
	H1-02	Terminal 4 Selection (Terminal 4 Sel)	00~77	1	14	Multi-function input (terminal 4) (same as H1-01)	x	B	B	B	B	
	H1-03	Terminal 5 Selection (Terminal 5 Sel)	00~77	1	3 (0) (Note 15)	Multi-function input (terminal 5) (same as H1-01)	x	B	B	B	B	

Function	Parameter No.	Name (Digital Operator Display)	Setting Range	Setting Unit	Factory Setting	Remarks (Digital Operator Display)	Change during Operation o: Enabled x: Disabled	Parameter Access Level				User Setting	
								V/f	V/f w/ PG	Open Loop Vector	Flux Vector		
	H1-04	Terminal 6 Selection (Terminal 6 Sel)	00~77	1	4 (3) (Note 15)	—	x	B	B	B	B		
	H1-05	Terminal 7 Selection (Terminal 7 Sel)	00~77	1	6 (4) (Note 15)	—	x	B	B	B	B		
	H1-06	Terminal 8 Selection (Terminal 8 Sel)	00~77	1	8 (6) (Note 15)	—	x	B	B	B	B		
Note 15: Factory settings in the parentheses are values obtained at 3-wire initialization.													
Terminal	Function H2 Digital Outputs	H2-01	Multi-function Input Terminal 9-10 (Terminal 9 Sel)	00~37	1	0	Multi-function output 1 (terminal 9, terminal 10) (same as F5-01)	x	B	B	B	B	
		H2-02	Multi-function Input Terminal 25 (Terminal 25 Sel)	00~37	1	1	Multi-function output 2 (terminal 25, terminal 27) (same as F5-01)	x	B	B	B	B	
		H2-03	Multi-function Input Terminal 26 (Terminal 26 Sel)	00~37	1	2	Multi-function output 3 (terminal 26, terminal 27) (same as F5-01)	x	B	B	B	B	
	Function H3 Analog Inputs	H3-01	Signal Level Selection Terminal 13 (Term 13 Signal)	0, 1	1	0	0: (0 - 10 VDC) 1: (-10 +10 VDC)	x	B	B	B	B	
		H3-02	(Terminal 13 Gain)	0.0~1000.0	0.1%	100.0	Frequency reference gain of AI-14U, AI-14B (3ch addition input), DI-08, and DI-16 is common.	o	B	B	B	B	
		H3-03	(Terminal 13 Bias)	-100.0 ~ +100.0	0.1%	0.0	Frequency reference gain of AI-14U, AI-14B (3ch addition input), DI-08, and DI-16 is common.	o	B	B	B	B	
		H3-04	Terminal 16 Signal Level Selection (Term 16 Signal)	0, 1	1	0	0: (0 - 10 VDC) 1: (-10 +10 VDC)	x	B	B	B	B	
		H3-05	Terminal 16 Multi-function Analog Input (Terminal 16 Sel)	0~1F	1	0	Multi-function analog input selection (terminal 16) 0: Auxiliary Reference 1: Frequency Gain 2: Frequency Bias 4: Voltage Bias 5: Accel/Decel Change 6: DC Brake Current 7: Overtorque Level 8: Stall Prevention Level 9: Reference Lower Limit A: Jump Frequency B: PID Feedback C: PID Setpoint D: Frequency Bias 2 10: Forward Torque Limit 11: Reverse Torque Limit 12: Regenerative Torque Limit 13: Torque reference 14: Torque Compensation 15: Forward/Reverse Torque Limit 1F: Not Used	x	B	B	B	B	

Function	Parameter No.	Name (Digital Operator Display)	Setting Range	Setting Unit	Factory Setting	Remarks (Digital Operator Display)	Change during Operation o: Enabled x: Disabled	Parameter Access Level				User Setting
								V/f	V/f w/ PG	Open Loop Vector	Flux Vector	
Terminal Analog Inputs	H3-06	(Terminal 16 Gain)	0.0~1000.0	0.1%	100.0	—	o	B	B	B	B	
	H3-07	(Terminal 16 Bias)	-100.0~+100.0	0.1%	0.0	—	o	B	B	B	B	
	H3-08	Signal Level Selection Terminal 14 (Term 14 Signal)	0, 1, 2	1	2	0: (0 - 10 VDC) 1: (-10 +10 VDC) 2: (4 - 20 mA)	x	A	A	A	A	
	H3-09	Multi-function Analog Input Terminal 14 (Terminal 14 Sel)	1~1F	1	1F	The function choices for terminal 14 are the same as the choices for terminal 16 [see H3-05], except that [setting 0] "Auxiliary Reference" is not available.	x	A	A	A	A	
	H3-10	Terminal 14 Gain (Terminal 14 Gain)	0.0~1000.0	0.1%	100.0	—	o	A	A	A	A	
	H3-11	Terminal 14 Bias (Terminal 14 Bias)	-100.0~+100.0	0.1%	0.0	—	o	A	A	A	A	
	H3-12	Analog Input Filter Time Constant (Filter Avg Time)	0.00~2.00	0.01s	0.00	—	x	A	A	A	A	

Function	Parameter No.	Name (Digital Operator Display)	Setting Range	Setting Unit	Factory Setting	Remarks (Digital Operator Display)	Change during Operation o: Enabled x: Disabled	Parameter Access Level				User Setting
								V/f	V/f w/ PG	Open Loop Vector	Flux Vector	
Group H Terminal Function Function H4 Analog Outputs	H4-01	Monitor Selection Terminal 21 (Terminal 21 Sel)	1~38	1	2	Analog output selection (terminal 21 (same as F4-01) 1: Frequency reference 2: Output frequency 3: Inverter output current 5: Motor speed 6: Output voltage 7: DC bus voltage 8: Output power 9: Torque reference (internal) 15: External terminal 13 input voltage 16: External terminal 14 input voltage 17: External terminal 16 input voltage 18: Motor secondary current (Iq) 19: Motor excitation current (Id) 20: Primary frequency after SFS 21: Speed controller ASR input 22: Speed controller ASR output 23: Speed deviation 24: PID feedback 26: Voltage reference (Vq output) 27: Voltage reference (Vd output) 31: Not Used 32: ACR (q) Output 33: ACR (d) Output 36: PID Input <1110> 37: PID Output <1110> 38: PID Reference <1110>	x	B	B	B	B	
	H4-02	Terminal 21 Output Gain (Terminal 21 Gain)	0.00~2.50	0.01	1.00	—	o	B	B	B	B	
	H4-03	Terminal 21 Output Bias (Terminal 21 Bias)	-10.0~+10.0	0.0%	0.0	—	o	B	B	B	B	
	H4-04	Terminal 23 Monitor (Terminal 23 Sel)	1~38	1	3	Analog output selection (terminal 23) (same as H4-01)	x	B	B	B	B	
	H4-05	Terminal 23 Output Gain (Terminal 23 Gain)	0.00~2.50	0.01	0.50	—	o	B	B	B	B	
	H4-06	Terminal 23 Output Bias (Terminal 23 Bias)	-10.0~+10.0	0.1%	0.0	—	o	B	B	B	B	
	H4-07	Analog Output Signal Selection (AO Level Select)	0, 1	1	0	0: (0 - +10 VDC) 1: (-10V +10 VDC)	x	B	B	B	B	

Function	Parameter No.	Name (Digital Operator Display)	Setting Range	Setting Unit	Factory Setting	Remarks (Digital Operator Display)	Change during Operation o: Enabled x: Disabled	Parameter Access Level				User Setting
								V/f	V/f w/ PG	Open Loop Vector	Flux Vector	
Group H Terminal Function Function H5 Serial Com Setup MODBUS Communication	H5-01	Station Address (Serial Comm Adr)	0~20	1	1F	—	x	A	A	A	A	
	H5-02	Communication Speed Selection (Serial Baud Rate)	0~4	0	3	0 : (1200 Baud) 1 : (2400 Baud) 2 : (4800 Baud) 3 : (9600 Baud) 4 : (19200 Baud) <1110>	x	A	A	A	A	
	H5-03	Communication Parity Selection (Serial Com Sel)	0, 1, 2	1	0	0 : (No Parity) 1 : (Even Parity) 2 : (Odd Parity)	x	A	A	A	A	
	H5-04	Stopping Method After Communication Error (Serial Fault Sel)	0~3	1	3	0: (Ramp to Stop) 1: (Coast to Stop) 2: (Fast - Stop) 3: (Alarm Only)	x	A	A	A	A	
	H5-05	Timeover Detection (Serial Flt Dtct)	0, 1	1	1	0 : (Disabled) 1 : (Enabled)	x	A	A	A	A	
Protection Function L1 Motor Overload	L1-01	Motor Protection Selection (MOL Fault Select)	0, 1	1	1	0: (Disabled) 1: (Coast to Stop)	x	B	B	B	B	
	L1-02	Motor Protection Time Constant (MOL Time Const)	0.1~5.0 min.	0.1 min.	1.0	When O2-09=1 [American Spec] the setting range is 0.1~20min. The factory default setting then becomes 8 min. 8 min. is the operation time from a cold start.	x	B	B	B	B	
Protection Function L2 Power Loss Ride Through	L2-01	Momentary Power Loss Detection (PwrL Selection)	0, 1, 2	1	0	0 : (Disabled) 1 : Power loss ride through (PwrL RideThru t) 2 : (CPU Power Active)	x	B	B	B	B	
	L2-02	Momentary Power Loss Ride Through (PwrL Ridethru t)	0.0~2.0	0.1s	0.7**	** Factory setting differs depending on inverter capacity (02-04).	x	B	B	B	B	
	L2-03	Min. Baseblock Time (PwrL Baseblock t)	0.1~5.0	0.1s	0.5*	* Factory setting differs depending on inverter capacity. Lower limit of setting range is changed from 0 to 0.1. <1110>	x	B	B	B	B	
	L2-04	Voltage Recovery Time (PwrL V/F Ramp t)	0.0~5.0	0.1s	0.3*	* Factory setting differs depending on inverter capacity (02-04).	x	A	A	A	A	
	L2-05	Undervoltage Detection Level (PUV Det Level)	150~210	1V	190*	*Voltage Class 200V class=190V Det level 400V class=190V x 2= 380V level 575V class=190x575/200=546 level	x	A	A	A	A	
	L2-06	KEB Deceleration Rate (KEB Frequency)	0.0~100.0	0.1%	0.0	—	x	A	A	A	A	

Function	Parameter No.	Name (Digital Operator Display)	Setting Range	Setting Unit	Factory Setting	Remarks (Digital Operator Display)	Change during Operation o: Enabled x: Disabled	Parameter Access Level				User Setting
								V/f	V/f w/ PG	Open Loop Vector	Flux Vector	
Protection Function L3 Stall Prevention Function	L3-01	Stall Prevention During Acceleration (StallP Accel Sel)	0, 1, 2	1	1	0: (Disabled) 1: (General Purpose) 2: (Intelligent)	x	B	B	B	-	
	L3-02	Stall Prevention Level During Acceleration (StallP Accel Lvl)	0~200	1%	150	—	x	B	B	B	-	
	L3-03	Stall Prevention Limit During Acceleration (StallP CHP Lvl)	0~100	1%	50	—	x	A	A	A	-	
	L3-04	Stall Prevention During Deceleration (StallP Decel Sel)	0, 1, 2, 3	1	1	0: (Disabled) 1: (General Purpose) 2: (Intelligent) <1110> can use setting 2 for all control modes A102=0,1,2,3 3: With braking resistor (Stall prev w/R) When in Vector w/PG A1-02=3 setting 3 cannot be set with braking resistor and with stall prevention.	x	B	B	B	B	
	L3-05	Stall Prevention Selection during Running (StallP Run Sel)	0, 1, 2	1	1	0: (Disabled) 1: (Decel Time 1) C1-02 2: (Decel Time 2) C1-04	x	B	B	-	-	
	L3-06	Stall Prevention Level during Running (StallP Run Level)	30~200	1%	160	—	x	B	B	-	-	
	L3-07	Stall Prevention Function P Gain (StallP Gain)	0.10~2.00	0.01	1.00	—	x	F	F	-	-	
	L3-08	Stall Prevention Function Integral Time (StallP Intg Time)	10~250	1 ms	100	—	x	F	F	-	-	

Function	Parameter No.	Name (Digital Operator Display)	Setting Range	Setting Unit	Factory Setting	Remarks (Digital Operator Display)	Change during Operation o: Enabled x: Disabled	Parameter Access Level				User Setting	
								V/f	V/f w/ PG	Open Loop Vector	Flux Vector		
Protection	Function L4 Reference Detection	L4-01	Frequency Detection Level (Spd Agree Level)	0.0~400.0	0.1Hz	0.0	—	x	B	B	B	B	
		L4-02	Frequency Detection Width (Spd Agree Width)	0.0~20.0	0.1Hz	2.0	—	x	B	B	B	B	
		L4-03	Frequency Detection Level ± (Spd Agree Lvl ±)	-400.0 ~ +400.0	0.1Hz	0.0	—	x	A	A	A	A	
		L4-04	Frequency Detection Width ± (Spd Agree Wdth ±)	0.0~20.0	0.1Hz	2.0	—	x	A	A	A	A	
		L4-05	Frequency Loss Detection Selection (Ref Loss Sel)	0, 1	1	0	0: (Stop) 1: (Run@ 80% PrevRef)	x	A	A	A	A	
	Function L5 Fault Restart	L5-01	Number of Auto Restart Attempts (Num of Restarts)	0~10	1	0	—	x	B	B	B	B	
		L5-02	Auto Restart Operation Selection (Restart Sel)	0, 1	1	0	0: (No Flt Relay) 1: (Flt Relay Active)	x	B	B	B	B	
	Function L6 Torque Detection	L6-01	Overtorque Detection Selection 1 (Torq Det 1 Sel)	0~4	1	0	0: (Disabled) 1: (@SpdAgree - Alm) Detected during speed agree only. Operation continues after detection and OL3 flashes on display. 2: (At RUN - Alarm) Overtorque detection during running. Operation continues after detection and OL3 flashes on the display. 3: (@SpdAgree - Flt) Detected during the speed agree only. Inverter trips on OL3, output is shut OFF. 4: (At RUN - Fault) Detected during running, and the inverter trips on OL3. Output is shut OFF.	x	B	B	B	B	

Function	Parameter No.	Name (Digital Operator Display)	Setting Range	Setting Unit	Factory Setting	Remarks (Digital Operator Display)	Change during Operation o: Enabled x: Disabled	Parameter Access Level				User Setting	
								V/f	V/f w/ PG	Open Loop Vector	Flux Vector		
Protection	Function L6 Torque Detection	L6-02	Overtorque Detection Level 1 (Torq Det 1 Lvl)	0~300	1%	150	—	x	B	B	B	B	
		L6-03	Overtorque Detection Time 1 (Torq Det 1 Time)	0.0~10.0	0.1s	0.1	—	x	B	B	B	B	
		L6-04	Overtorque Detection Selection 2 (Torq Det 2 Sel)	0~4	1	0	0: (Disabled) 1: (@SpdAgree - Alm) Detected during speed agree only. Operation continues after detection and OL4 flashes on display. 2: (At RUN - Alarm) Overtorque detection during running. Operation continues after detection and OL4 flashes on the display. 3: (@SpdAgree - Flt) Detected during the speed agree only. Inverter trips on OL4, output is shut OFF. 4: (At RUN - Fault) Detected during running, and the inverter trips on OL4. Output is shut OFF.	x	A	A	A	A	
		L6-05	Overtorque Detection Level 2 (Torq Det 2 Lvl)	0~300	1%	150	—	x	A	A	A	A	
		L6-06	Overtorque Detection Time 2 (Torq Det 2 Time)	0.0~10.0	0.1s	0.1	—	x	A	A	A	A	
		Function L7 Torque Limit	L7-01	Forward Torque Limit (Torq Limit Fwd)	0~300	1%	200	—	x	-	-	B	B
	L7-02		Reverse Torque Limit (Torq Limit Rev)	0~300	1%	200	—	x	-	-	B	B	
	L7-03		Forward Regenerative Torque Limit (Torq Lmt Fwd Rgn)	0~300	1%	200	—	x	-	-	B	B	
	L7-04		Reverse Regenerative Torque Limit (Torq Lmt Rev Rgn)	0~300	1%	200	—	x	-	-	B	B	

Function	Parameter No.	Name (Digital Operator Display)	Setting Range	Setting Unit	Factory Setting	Remarks (Digital Operator Display)	Change during Operation o: Enabled x: Disabled	Parameter Access Level				User Setting
								V/f	V/f w/ PG	Open Loop Vector	Flux Vector	
Protection Function L8 Hardware Protection	L8-01	Internal DB Resistor Protection Selection (DB Resistor Prot)	0, 1	1	0	0: (Not Provided) 1: (Provided)	x	B	B	B	B	
	L8-02	Overheat Pre-alarm Level (OH Pre-Alarm Lvl)	50~130	1 deg C	95 C*	*Factory setting depends on inverter model [02-04].	x	A	A	A	A	
	L8-03	Operation Selection after OH Pre-alarm (OH Pre-Alarm Sel)	0~3	1	3	0: (Ramp to Stop) using C1-02 1: (Coast to Stop) 2: (Fast-Stop) using C1-09 3: (Alarm Only) display flashes OH Heatsink Ovrtemp	x	A	A	A	A	
	L8-05	Input Phase Loss Protection (PH Loss In Sel)	0, 1	1	0	0: (Disabled) 1: (Enabled)	x	A	A	A	A	
	L8-07	Output Phase Loss Protection (PH Loss Out Sel)	0, 1	1	0*	0: (Disabled) 1: (Enabled) *When 02-09=1, the factory default setting is 1.	x	A	A	A	A	
Protection Function L8 Hardware Protection	L8-10	Short-circuit Protection Selection (Ground Fault Sel)	0, 1	1	1	0: (Disabled) 1: (Enabled)	x	A	A	A	A	
	L8-17	IGBT Protection Selection at Low Frequency (Prctct@L - Spd)	0, 1	1	1*	0: Conventional 1: (Lower fc) Carrier frequency is decreased when f _{out} ≤ 10Hz and the load is > 100% iac. 2: (Short term OL2) OL occurs after 2 seconds during low speed [f _{out} ≤ 6Hz] current limit. 3: (I-Limit=150%) Current limit is set to 150% of the inverter rated current. < G5 + > Addition * When 02-09=1 factory setting is 1. * When 02-09=2 factory setting is 2.	x	A	A	A	-	
	L8-19 <1110>	OL2 Characteristics Selection at Low Speed (OL2 Chara@L-Spd)	0, 1	1	0	0: (Disabled) Low frequency OL disabled 1: (Enabled) Low frequency OL enabled	x	A	A	A	A	

Function	Parameter No.	Name (Digital Operator Display)	Setting Range	Setting Unit	Factory Setting	Remarks (Digital Operator Display)	Change during Operation o: Enabled x: Disabled	Parameter Access Level				User Setting	
								V/f	V/f w/ PG	Open Loop Vector	Flux Vector		
Operator	Function o1 Monitor Selection					Monitor selection 4: Control method 5: Motor speed 6: Output voltage 7: DC bus voltage 8: Output power 9: Torque reference (internal) 10: Input terminal status 11: Output terminal status 12: Internal Control Status 1 13: Elapsed time 14: Flash software ID number 15: External terminal 13 input voltage 16: External terminal 14 input voltage 17: External terminal 16 input voltage 18: Motor secondary current (Iq) 19: Motor excitation current (Id) 20: Primary frequency after SFS 21: Speed controller ASR input 22: Speed controller ASR output 23: Speed deviation 24: PID feedback 25: DI-16 reference 26: Voltage reference (Vq output) 27: Voltage reference (Vd output) 28: CPU ID number	o	B	B	B	B		
		O1-01	Monitor Selection (User Monitor Sel)	4~39	1	6							
	Function o2 Key Selections						1: (Frequency Ref) 2: (Output Freq) 3: (Output Current) 4: (User Monitor)	o	B	B	B	B	
		O1-02	Monitor Selection after Power Up (Power-On Monitor)	1~4	1	1							
		O1-03	Frequency Units of Reference Setting and Monitor (Display Scaling)	0~39999	1	0	—	x	B	B	B	B	
		O1-04	(Display Units)	0, 1	1	0	0: (Hertz) 1: (RPM)	x	-	-	-	B	
		O1-05	Parameter No. Display Selection (Address Display)	0, 1	1	0	0: (Parameter Number) 1: (Memobus Address)	x	A	A	A	A	
	O2-01	LOCAL/REMOTE Key Enable/Disable (Local/Remote Key)	0, 1	1	1	0: (Disabled) 1: (Enabled)	x	B	B	B	B		
	O2-02	STOP Key Function Selection (Oper STOP Key)	0, 1	1	1	0: (Disabled) When the inverter is operated from the digital operator. 1: (Enabled) Always enabled.	x	B	B	B	B		

Function	Parameter No.	Name (Digital Operator Display)	Setting Range	Setting Unit	Factory Setting	Remarks (Digital Operator Display)	Change during Operation o: Enabled x: Disabled	Parameter Access Level				User Setting
								V/f	V/f w/ PG	Open Loop Vector	Flux Vector	
Operator Function o2 Key Selection	02-03	User Parameter Initialization Selection (User Defaults)	0, 1, 2	1	0	0: (No Change) manufacturer default values used 1: (Set Defaults) Sets user specified value as default. 2: (Clear All) Clears user defaults	x	B	B	B	B	
	02-04	kVA Selection (Inverter Model #)	0~FF	1	-*	* Not initialized. Sets the inverter capacity according to the model number.	x	B	B	B	B	
	02-05	Frequency Reference Setting Method Selection (Operator M.O.P.)	0, 1	1	0	0: (Disabled) 1: (Enabled)	x	A	A	A	A	
	02-06	Operation Selection When Digital Operator is Disconnected (Oper Detection)	0, 1	1	0*	0: (Disabled) Operation continues even if the digital operator is disconnected. 1: (Enabled) Inverter fault when the digital operator is disconnected. * When 02-09=1, the value is 1.	x	A	A	A	A	
	02-07	Elapsed Timer Setting (Elapsed Time Set)	0~65535	1 hour	—	—	x	A	A	A	A	
	02-08	Elapsed Timer Selection (Elapsed Time Run)	0, 1	1	0	0: (Power - On Time) 1: (Running Time)	x	A	A	A	A	
	02-09	Initialization Mode Selection (Init Mode Sel)	0~3	1	0	0: (Japanese spec) 1: (American spec) 2: (European spec) 3: (OMRON spec) When 02-09 = 1 or 2, it is added by <1032>. When 02-09 = 0 or 3, it is added by <1040>.	x	A	A	A	A	

A.4 BRAKING CONNECTION DIAGRAMS

Braking Resistor Unit

230V: G5U20P4 to 27P5
460V: G5U40P4 to 4015
575V: G5U51P5 to 5022

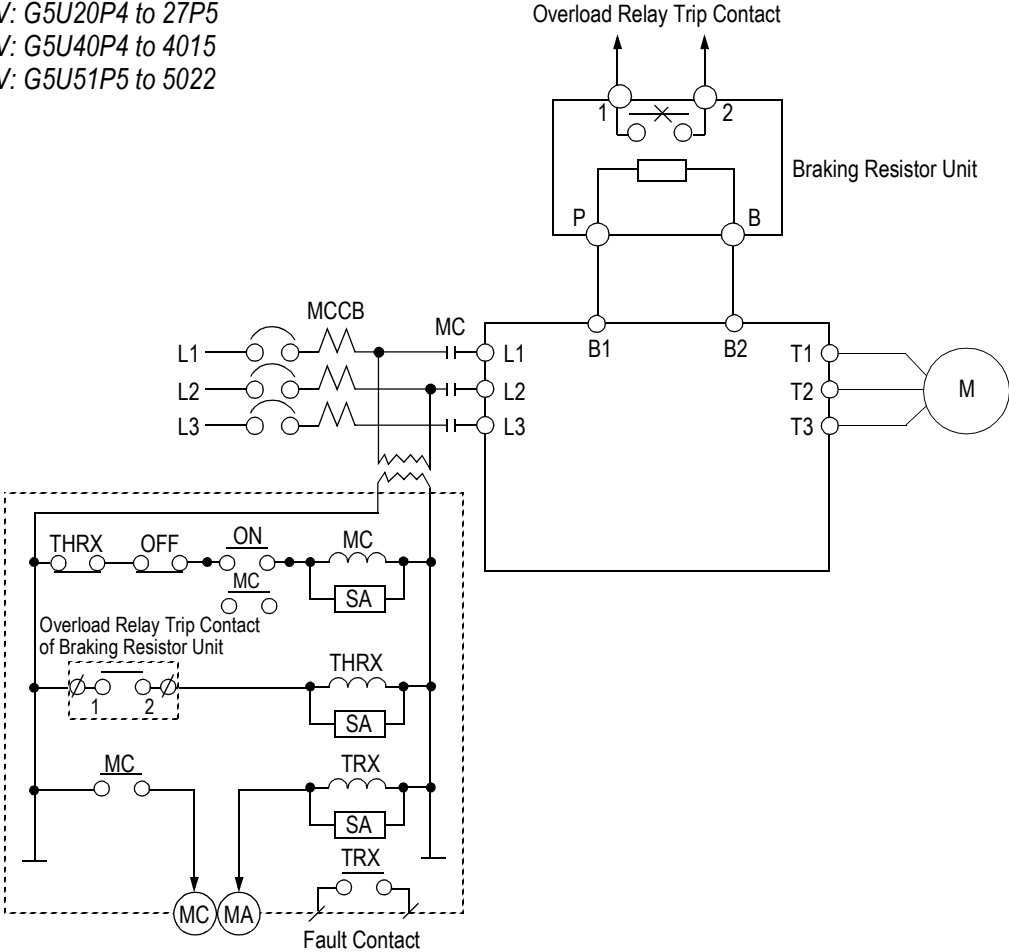

Figure 24 External Control Circuit for G5 Braking Resistor Connection

230V: G5U2011 to 2075
460V: G5U4018 to 4300
575V: G5U5030 to 5160

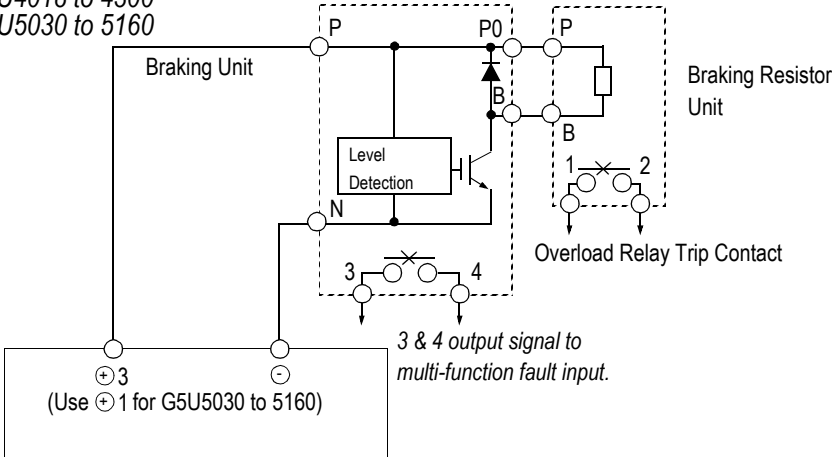

Figure 25 External Control Circuit for G5 Braking Unit Connection

A.5 CE CONFORMANCE INFORMATION (APPLICABLE TO 460V MODELS ONLY)

CE CONFORMANCE - Low Voltage Directive (LVD) Compliance

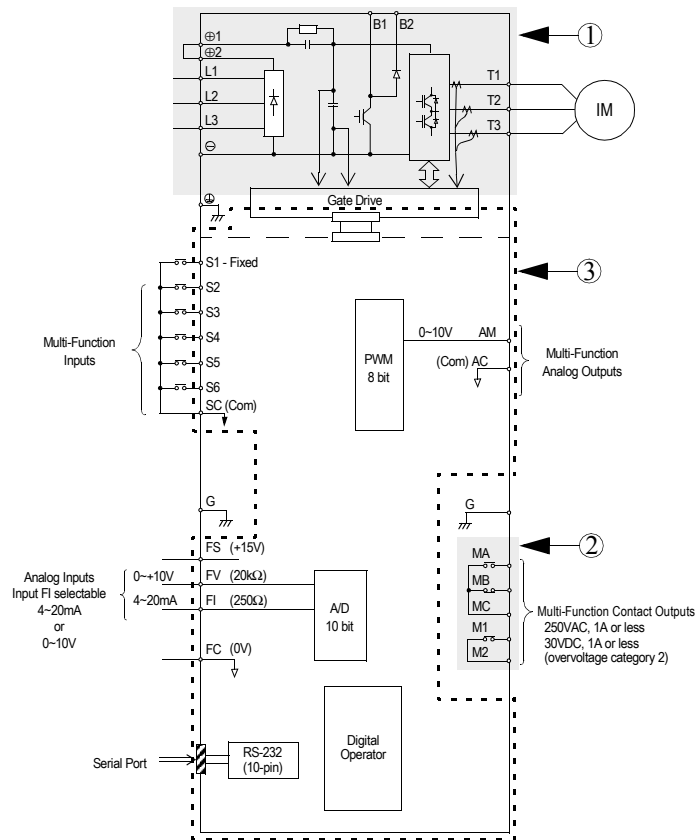

Figure 26 VS-616G5 Terminal Diagram

- ① These circuits are hazardous and are separated from accessible surface by protective separation.
- ② These circuits are not separated from hazardous circuits by protective separation, but only with basic insulation. These circuits cannot be accessed and must not be interconnected with any circuits which are accessible, unless they are isolated from accessible circuits by supplemental insulation. These circuits can be connected only to the following circuits:
 30VDC or less (overvoltage category 2)
 250VAC or less (overvoltage category 2)
- ③ These circuits are not separated from hazardous circuits by protective separation, but only with basic insulation. These circuits cannot be accessed and must not be interconnected with any circuits which are accessible, unless they are isolated from accessible circuits by supplemental insulation.

CE CONFORMANCE - Electro-Magnetic Compatibility (EMC) Compliance

In order to conform to EMC standards, exclusive-use methods are required for line filter application, cable shielding and inverter installation. An outline of the methods follows.

The line filter and the inverter must be mounted on the same metal plate. The filter should be mounted as close to the inverter as practical. Keep cable as short as possible. The metal plate should be securely grounded. The ground of the line filter and inverter must be bonded to the metal plate with as much area as possible.

For line power input cable, screened cable is recommended at least within the panel. The screen of the cable should be connected to a solid ground. For the motor cable, screened cable (max. 20m) must be used and the screen of the motor cable is connected to ground at both ends by a short connection, using as large an area as practical.

For a more detailed explanation, please refer to “Making YASKAWA Inverter Products Conform with EMC Directive” (EZZ006908).

The following table and figures show the line filter list for EMC standards and the installation/wiring of inverter and line filter.

Line Filter List for EMC Standards

Inverter Model CIMR-G5Uxxxx	Line Filter (Manufactured by Schaffner)			
	Model	Rated Current (A)	Mass (kg)	Dimensions (mm) W × D × H
40P4	FS4874-7/07	7	1.1	50 × 126 × 255
40P7				
41P5				
42P2	FS4874-18/07	18	1.7	55 × 142 × 305
43P7				
44P0				
45P5	FS4874-30/07	30	1.8	60 × 150 × 335
47P5				
4011	FS4874-42/07	42	2.8	70 × 185 × 329
4015				
4018	FS4874-55/07	55	3.1	80 × 185 × 329
4022	FS4874-75/34	75	4.0	80 × 220 × 329
4030				
4037	FS4874-100/35	100	5.5	90 × 220 × 379
4045	FS4874-130/35	130	7.5	110 × 240 × 429
4055	FS4874-180/07	180	11	110 × 240 × 438
4075	FS4874-300/99	300	15	300 × 564 × 160
4110	FS4874-400/99	400	22	300 × 564 × 160
4160				
4185	FS4874-500/99	500	19.5	300 × 564 × 160
4220	FS4874-600/99	600	20.5	300 × 564 × 160
4300	FS4874-900/99	900	33.5	300 × 564 × 160

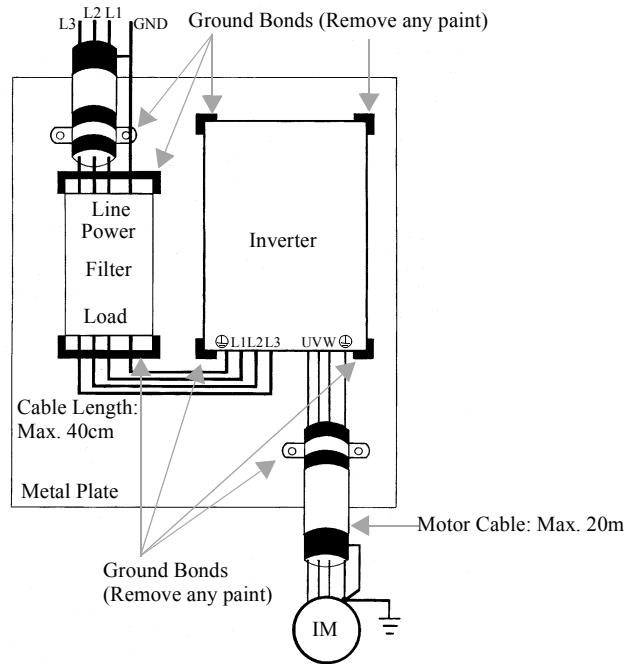

Fig. 27 Installation of Line Filter and Inverter (Models CIMR-G5U 40P4 to 4015)

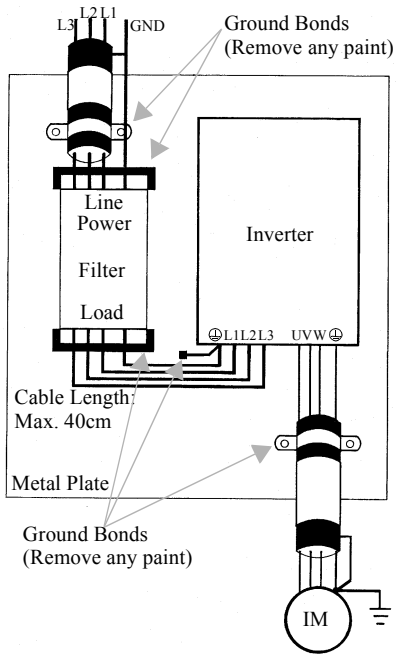

Fig. 28 Installation of Line Filter and Inverter (Models CIMR-G5U 4018 to 4300)

Safety Warnings and Operating Information for Inverters

Introduction

Depending on their protection rating configuration, parts of inverters can have live, uninsulated and hot surfaces during operation. If housing components, the control unit or terminal covers are removed, incorrect installation and operation can lead to serious injuries and damage to other installations. It is thus absolutely essential to observe all the warnings and instructions in the operating manual. Installation, setup and maintenance should only be performed by properly qualified staff. (IEC 364 / Cenelec HD 384 or DIN VDE 0100 and IEC 664 or DIN VDE. The applicable national safety and accident prevention regulations must also be observed.) For the purpose of observance of the safety requirements qualified staff are defined as individuals who are familiar with the installation, setup and operation of the equipment and who have the proper qualifications for this work.

Proper use for intended purpose

Inverters are designed for installation in electrical systems or machines. A converter installed in a machine may only be activated if the machine conforms to the provisions of EU directive 89/392/EEC (machine directives). EN 60204 must also be observed. The converter may also only be operated if the requirements of the EMC directive (89/336/EEC) are also satisfied. This frequency converter conforms to the requirements of the low-voltage directive, 73/23/EEC. The harmonized standards of the prEN 50178/DIN VDE 0160 series have been applied, in combination with EN 660439-1 / VDE 06600 Part 500 and EN 60146 / VDE 0558. The specifications on the ratings plate and the specifications and connection requirements described in the documentation must be observed at all times.

Transportation and storage

All instructions for transport, storage and proper handling must be observed. Climatic and environmental conditions must conform to the requirements of prEN 50178.

Installation

The converters must be installed and cooled in compliance with the regulations outlines and referred to in the documentation. The cooling air flow direction is an important requirement that must be observed. This means that the unit may only be installed and operated in the specified orientation (e.g. upright). All distances specified must also be observed. The converters must be protected against excessive stresses. No components may be bent and no distances required for proper insulation may be changed. To prevent the risk of static electricity damage never touch electronic components or contacts.

Electrical connections

All national safety regulations (e.g. VBG 4) must be observed when working on live equipment. The electrical installation of the units must conform to the applicable regulations. For further information please refer to the documentation. In particular, please take care to observe all installation instructions as regards proper EMC immunity, e.g. for shielding, earthing, location of filters and cable routing. This also applies for equipment with CE approvals. Compliance with the EMC legislation limits is the responsibility of the machine or system manufacturer.

RCCBs

For information on the use of RCCBs with inverters please contact your supplier or Yaskawa representative.

Operation

In some systems it may be necessary to install additional monitoring and protective facilities to comply with the applicable safety and accident prevention regulations. The only changes permitted are to the operator software of the inverters. Please note that the capacitors can remain charged for up to around 5 minutes after the frequency converter has been disconnected from the power supply. You should thus always wait for a short period before opening the unit and touching the electrical connections.

EU Manufacturer's Declaration

Products

Static inverter, series VS-616G5

Scope

YASKAWA inverters are components (BDM*, defined by IEC 22G/21CDV) designed exclusively for installation in machines or systems (end products) by qualified re-users (e.g. mechanical engineering manufacturers).

Responsibility

As a component manufacturer we are responsible for the provision of installation instructions. These can be found in the installation guidelines publication EZZ006908 (a Yaskawa publication free upon request).

Our products have been tested by authorized bodies pursuant to the requirements of the standards listed below. The products conform to these standards, subject to due and proper observation of the installation instructions provided in section 10 of this manual:

Immunity — EMC resistance pursuant to EN50082-2, Part 2:

EN 61000-4-2 Resistance to static discharge

EN 61000-4-4 Resistance to high-speed transients and bursts

EN 61000-4-8 Testing of resistance to magnetic fields with power systems frequencies

ENV 50140 Resistance to high-frequency magnetic fields

ENV 50141 Resistance to conducted interference

Emissions — EMC interference emissions pursuant to EN50081-2, Part 2:

EN 55011 Class A or B limit curve under the conditions described in the operating instructions in the installation guidelines, EZZ006908.

YASKAWA Electric Europe GmbH
Am Kronberger Hang 2
65824 Schwalbach am Taunus
Germany

Always observe all the safety instructions provided in this product documentation!

* **AdÜ:** Abkürzung bitte kontrollieren.

This page intentionally left blank.



YASKAWA ELECTRIC AMERICA, INC.

Chicago-Corporate Headquarters 2121 Norman Drive South, Waukegan, IL 60085, U.S.A.
Phone: (847) 887-7000 Fax: (847) 887-7310 Internet: <http://www.yaskawa.com>

MOTOMAN INC.

805 Liberty Lane, West Carrollton, OH 45449, U.S.A.
Phone: (937) 847-6200 Fax: (937) 847-6277

YASKAWA ELECTRIC CORPORATION

New Pier Takeshiba South Tower, 1-16-1, Kaigan, Minatoku, Tokyo, 105-0022, Japan
Phone: 81-3-5402-4511 Fax: 81-3-5402-4580 Internet: <http://www.yaskawa.co.jp>

YASKAWA ELETRICO DO BRASIL COMERCIO LTDA.

Avenida Fagundes Filho, 620 Bairro Saude Sao Paulo-SP, Brasil CEP: 04304-000
Phone: 55-11-5071-2552 Fax: 55-11-5581-8795 E-mail: yaskawabrasil@originet.com.br

YASKAWA ELECTRIC EUROPE GmbH

Am Kronberger Hang 2, 65824 Schwalbach, Germany
Phone: 49-6196-569-300 Fax: 49-6196-888-301

MOTOMAN ROBOTICS AB

Box 504 S38525, Torsas, Sweden
Phone: 46-486-48800 Fax: 46-486-41410

MOTOMAN ROBOTEC GmbH

Kammerfeldstraße 1, 85391 Allershausen, Germany
Phone: 49-8166-900 Fax: 49-8166-9039

YASKAWA ELECTRIC UK LTD.

1 Hunt Hill Orchardton Woods Cumbernauld, G68 9LF, Scotland, United Kingdom
Phone: 44-12-3673-5000 Fax: 44-12-3645-8182

YASKAWA ELECTRIC KOREA CORPORATION

Paik Nam Bldg, 901 188-3, 1-Ga Euljiro, Joong-Gu, Seoul, Korea
Phone: 82-2-776-7844 Fax: 82-2-753-2639

YASKAWA ELECTRIC (SINGAPORE) PTE. LTD.

Head Office: 151 Lorong Chuan, #04-01, New Tech Park Singapore 556741, SINGAPORE
Phone: 65-282-3003 Fax: 65-289-3003

TAIPEI OFFICE (AND YATEC ENGINEERING CORPORATION)

10F 146 Sung Chiang Road, Taipei, Taiwan
Phone: 886-2-2563-0010 Fax: 886-2-2567-4677

YASKAWA JASON (HK) COMPANY LIMITED

Rm. 2909-10, Hong Kong Plaza, 186-191 Connaught Road West, Hong Kong
Phone: 852-2803-2385 Fax: 852-2547-5773

BEIJING OFFICE

Room No. 301 Office Building of Beijing International Club, 21
Jianguomanwai Avenue, Beijing 100020, China
Phone: 86-10-6532-1850 Fax: 86-10-6532-1851

SHANGHAI OFFICE

27 Hui He Road Shanghai 200437 China
Phone: 86-21-6553-6600 Fax: 86-21-6531-4242

SHANGHAI YASKAWA-TONJI M & E CO., LTD.

27 Hui He Road Shanghai 200437 China
Phone: 86-21-6533-2828 Fax: 86-21-6553-6677

BEIJING YASKAWA BEIKE AUTOMATION ENGINEERING CO., LTD.

30 Xue Yuan Road, Haidian, Beijing 100083 China
Phone: 86-10-6232-9943 Fax: 86-10-6234-5002

SHOUGANG MOTOMAN ROBOT CO., LTD.

7, Yongchang-North Street, Beijing Economic & Technological Development Area,
Beijing 100076 China
Phone: 86-10-6788-0551 Fax: 86-10-6788-2878